

Stainless Steel

*Cast Stainless Steel
Gate, Globe and Check Valves*

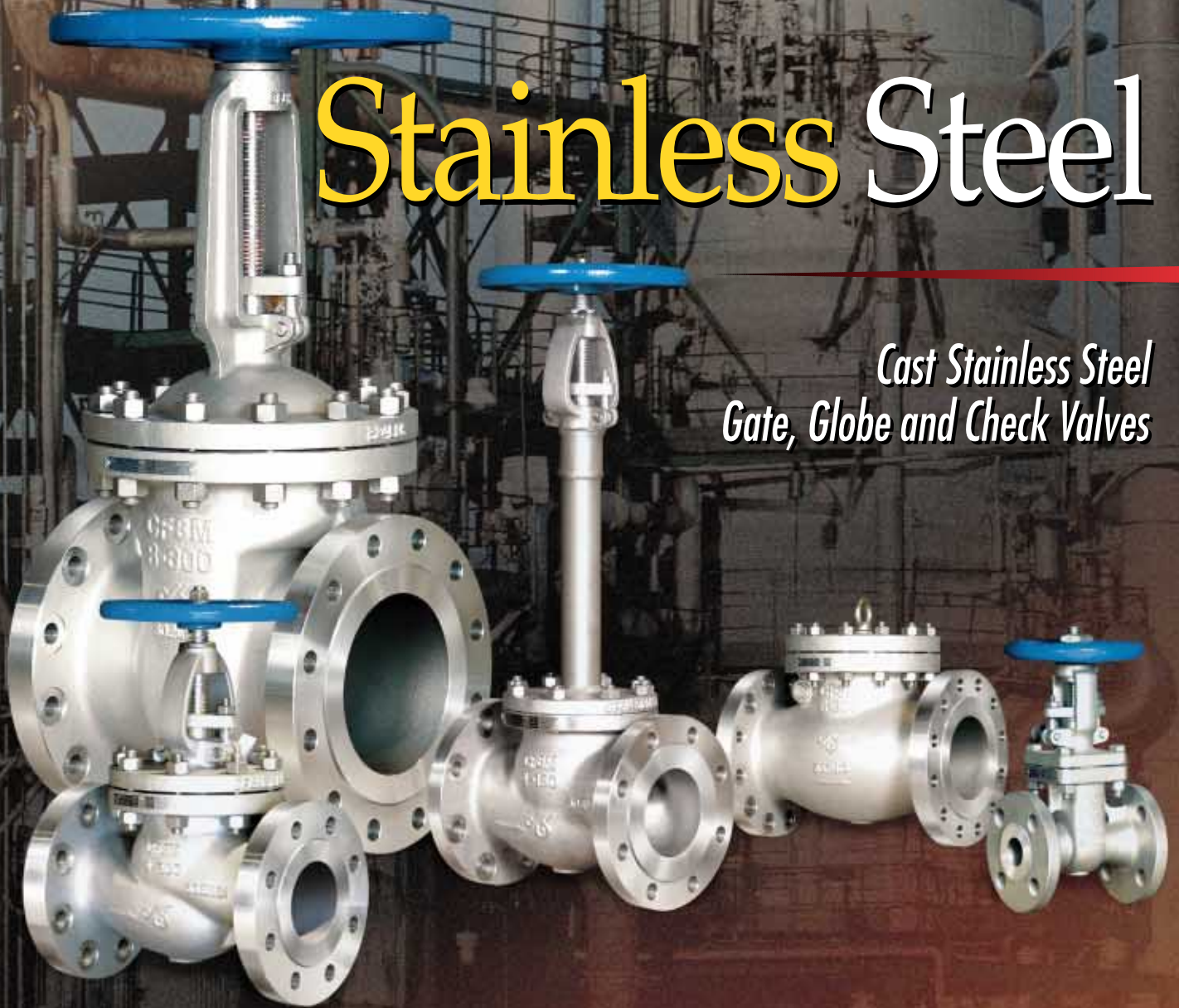

Standard Features of Stainless Steel Valves

Low Fugitive Emission Service

Stainless Steel Gate, Globe and Check Valves are designed and manufactured to ensure leakage of less than 100 ppm (parts per million) of volatile organic compounds.

Base line laboratory testing (static and cycle testing) has been performed establishing critical design parameters necessary to achieve low emission sealing in the stem packing seal area

for Gate and Globe Valves and in the bonnet gasket sealing area (cover gasket for Check Valves).

In-house testing procedures have been developed and are periodically performed to ensure that standard product design and manufacturing criteria consistently result in the Gate, Globe and Check Valve meeting a maximum of 100 ppm VOC leakage prior to shipment.

Critical Design and Manufacturing Controls Applied To Produce Low Emission Service Valves In Standard Products.

- Stem Straightness and Roundness
- Stem Surface Finish To Maximum 32 Ra
- Stuffing Box Surface Finish To Maximum 125 Ra
- Stuffing Box and Gland Cylindricity
- Self Centering Gland Design
- Gland Packing: Die-formed Graphite Rings with Braided Graphite Top and Bottom Wiper Rings, or Braided PTFE.
- Bonnet Gaskets:
 - Class 150 Gate, Globe & Check Valves: 316 SS Tanged Clad Graphite or PTFE
 - Class 300 & 600 Valves: 316 SS Spiral Wound or PTFE

Low Emission Design Options

Live Load Packing

For valves in service that require frequent cycling or high pressure/temperature variations (Graphite only), live loading can extend the service life between maintenance periods by requiring less frequent packing gland adjustments. Belleville springs are employed to provide constant packing gland stress.

Durable Bonnet Gasket Design

Stainless Steel valves are furnished with an encapsulated (tongue and groove) body-to-bonnet joint design on class 150, 300 and 600 gate, globe and check valves. Additionally, the relatively narrow ASME standard face to face dimension of class 150 flanged end gate valves presents a challenge in typical bonnet gasket designs normally resulting in the utilization of oval style bonnet gaskets.

Oval style gaskets, while typically used industry wide, are less durable due to differentiating radii.

Stainless Steel valves have been designed to overcome this problem by providing a body design that facilitates a fully symmetrical, round body-to-bonnet gasket contact surface area. This round bonnet gasket design, in pressure classes 150, 300 and 600, is an inherently stronger gasket than a typical oval gasket.

Packing System

Stainless Steel Gate and Globe valves use a combination of die-formed flexible graphite and inter-braided graphite in a predetermined arrangement to ensure an effective seal. Graphite packing achieves its maximum ability to isolate the atmosphere when it is contained within a chamber that is precise

in finish and dimension. Gate and Globe valves are manufactured with stem finishes better than 32 Ra and stuffing box wall finishes for 125 Ra. In addition, stem straightness and taper are closely controlled. Braided PTFE packing is also available as a standard valve packing - please specify at time of order.

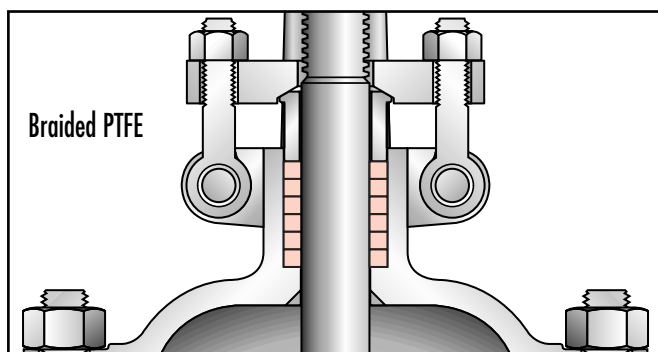
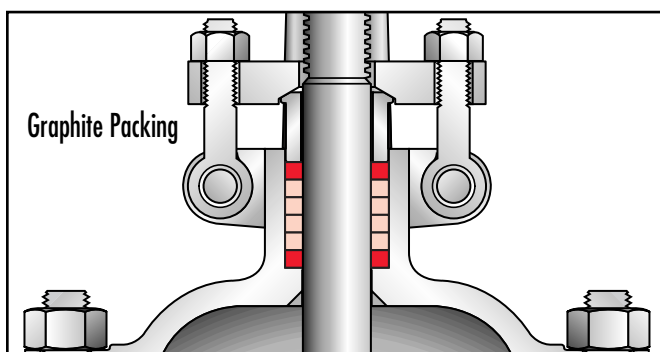

Testing, Modifications and Accessories for Stainless/Cryogenic Service

Available Modifications for Stainless Steel Valves

- Packing and Gasket Changes
- End Connection Modifications
- Gear Operator Mounting
- Trim Changes
- Actuation
- Cryogenic Gas Columns
- Hand Wheel Extensions
- PTFE Disc Inserts
- Drilled & Tapped Connections
- By-Pass Installations
- Pressure Equalizing
- Acid Shields
- Oxygen & Chlorine Cleaning & Packaging
- Weld End Bore Changes
- Customer Specified Coatings
- Chain Wheel Operator
- Double Block and Bleed

NDE Testing Available (In-House)

- Dye Penetrant Test
- Radiography
- PMI (Positive Material Identification)
- API Performance Testing

Stainless Steel Valves Standard Product Range with Zy-Gear Bevel Gear Chart

offers a broad range of standard commodity Stainless Steel Valves in flanged and weld end connections. This chart

for Zy-Gear operators is based on torque ratings for each valve at maximum differential pressure.

Valve Type	Pressure Class	Size Range	Bonnet	Disc	Zy-Gear
Gate	150	2"-48"	Bolted OS&Y	Flex	2"-12" - 107B 14"-24" - 207B
	300	2"-30"	Bolted OS&Y	Flex	2"-10" - 107B 12"-20" - 207B 24" - 307B
	600	2"-24"	Bolted OS&Y	Flex	2"-6" - 107B 8"-12" - 207B 14"-24" - 307B
Globe	150	2"-14"	Bolted OS&Y	Plug	2"-12" - 207B
	300	2"-12"	Bolted OS&Y	Plug	2"-12" - 207B
	600	2"-8"	Bolted OS&Y	Plug	2"-12" - 207B
Swing Check	150	2"-24"	Bolted	Swing	n/a
	300	2"-24"	Bolted	Swing	n/a
	600	2"-16"	Bolted	Swing	n/a



Industry inter-changeable pre-drilled mounting pattern per MSS SP101.

Conformance

NACE Compliance

The demand for valves to be resistant to sulfide stress cracking, and to perform in corrosive hydrocarbon environments, has become commonplace. Facilities handling H₂S bearing hydrocarbons have increased dramatically over recent years. Hydrogen sulfide concentration, total system pressure, application temperature, existence of elemental sulfur, and chloride content all have a bearing on appropriate material selection in this severe environment.

All Stainless Steel gate, globe and check valves, with standard API trim, have been proven reliable, and fully comply with NACE MR0175 2003. In order to ensure compliance with NACE MR0175 2003, customers must provide application specific operating conditions.

In addition, all Stainless Steel gate, globe and check valves, with standard API trim, fully comply with NACE MR0103 2003 and MR0175 2002 Edition.

Welding

Welding and weld repair operations are conducted in accordance with applicable ASTM material specifications and NACE (MR0175 2002 Edition) using procedures and personnel qualified to ASME Section IX.

Material Test Reports

Material test reports for Stainless Steel valves are available upon request. Material test reports meet the requirements of EN 10204 3.1b



General Design Specifications

Stainless Steel Valves are manufactured in strict accordance with the following standards:

- API 603/ASME B16.34
- API 600 Design

Please consult Zy-Tech Global Industries, Inc. for availability.

American Standard	Item Description
API 603/API 600	Shell wall thickness and general valve design specifications
ASME B16.34	General valve design: Globe and Check valves
ASME B16.34	Pressure temperature ratings
ASME B16.10	Face-to-face dimensions, End-to-end dimensions
ASME B16.5	End flange dimensions, Gasket contact facing
ASME B16.25	Welding end dimensions

Stainless Steel Metal and Alloy Designations

For Corrosion Resistant Valves

Type	ASME Designation
304L	A351 Grade CF3
304	A351 Grade CF8
316	A351 Grade CF8M
316L	A351 Grade CF3M
317	A351 Grade CG8M
317L	A351 Grade CG3M
321/347	A351 Grade CF8C
Alloy 20	A351 Grade CN7M
Duplex/Super Duplex	A351 Grade CD4MCu, A890 Grade 4A or 6A
HASTELLOY® C/B	A494 Grade CW12MW, A494 N12MV

Valves For Cryogenic Service

Applications such as liquefied natural gas, and other low temperature fluids, present special valve functionality challenges caused by extreme temperature conditions. Zy-Tech Global Industries' gate, globe and check valves that are designed for cryogenic services, are specially prepared and designed to overcome these challenges.

Appropriate component materials such as 304 SS (CF8) and 316 SS (CF8M) are normally used for body and trim, offering superior impact strength, and excellent corrosion resistance and heat loss properties. An extended bonnet and gas column design is also normally employed to provide thermal insulation at the stem seal and stem packing area. At sufficient length, this design feature places the functionality of the stem seal in the vapor zone of the liquid media providing safe and continuous valve operation.

A variety of body, trim, seat and seal materials are available for use in cryogenic service. Customer specified options, such as body cavity vent hole, special extension lengths and Kel-F materials, are also available upon request.

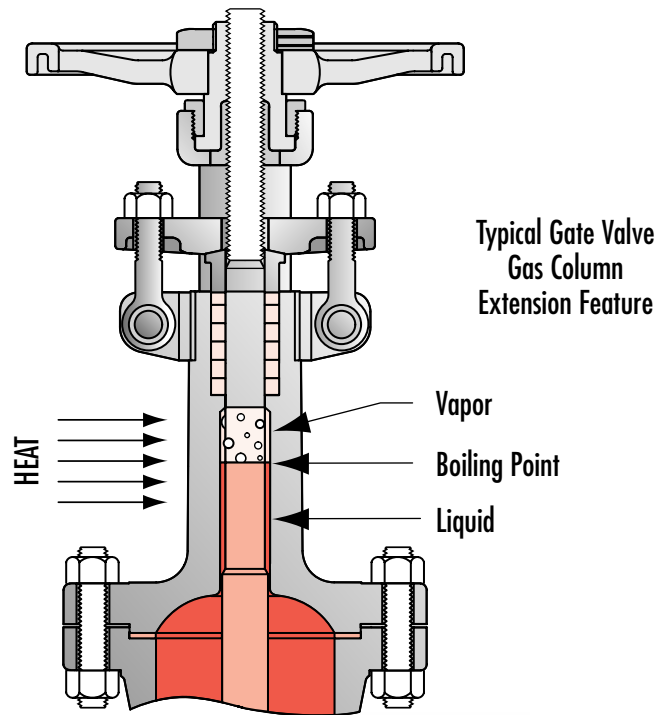

Table of Liquefied Gases

Type	Boiling Point °F
LNG	-270
Methane, CH ₄	-258
Oxygen, O ₂	-296
Argon, A	-303
Carbon Dioxide, CO ₂	-109
Air	-318
Nitrogen, N ₂	-320
Hydrogen, H ₂	-423
Helium, He	-452



Class 300 Cast Stainless Globe Valve



Class 800 Forged Stainless Gate Valve

Specifying Cast Stainless Steel Valve Figure Numbers

It's easy to specify Stainless Steel Valves. Just follow the example and use the figure number chart below to specify the valve you need.

Stainless Steel Example:

A 16" Gear Operated Class 150 Gate Valve with RTJ Flanged End Connections, A351 CF8M Stainless Steel Body, 316 Stainless Steel Trim with Half Hard Faced Trim Option, Graphoil® Packing and Gaskets, API 603 Design Conformance with no Specials specified.

DSI Series	Operation	Pressure Classes	End Connection	Body Material	Trim Material	Stellite® Option	Packing and Gasket Material	Specials	Design
DSI A	G B	37 C	R D	16 E	16 F	HFS G	H	I	J
DSI	No Denotation for Manual Operation and Check Valves G Gear Operated CW Chain Wheel Operated A Motor Operated	See Chart Below	No Denotation for Raised Face Flanged End 1/2 Weld End R RTJ Flanged Ends FF Flat Faced Ends	04 A351 CF8 04L A351 CF3 16 A351 CF8M 16L A351 CF3M 17 A351 CG8M 17L A351 CG3M 47 A351 CF8C A20 A351 CN7M	04 304SS 04L 304LSS 16 316SS 16L 316LSS 17 317SS 17L 317LSS 47 347SS A20 Alloy 20	HFS Half Hard Faced Trim U Full Hard Faced Trim	No Denotation for Graphoil® Packing and Gaskets T PTFE Packing and Gaskets	EB Extended Bonnet LD Locking Device BP Bypass N NACE (MR0175 2002 Edition) DD Double Disc Design EQ Equalization Line	No Denotation for API 603 Design H API 600 Design

Valve Type	Class	Code
Gate	150	37
	300	23
	600	66
Globe	150	133
	300	141
	600	161
Swing Check	150	137
	300	149
	600	165

See Codes Below for Stainless Steel Check Valves

Specials	Packing Material	Design
N NACE (MR0103) NACE (MR0175 2002 Edition)	No Denotation for Graphoil® Gaskets T PTFE Gaskets	No Denotation for B16.34 Design H API 600 Design

Gate Valves



Parts And Materials • Class 150, 300 & 600

Item	Part Name	CF8M	316L	317	317L	304	Alloy 20
1	Body	A351-CF8M	A351-CF3M	A351-CG8M	A351-CG3M	A351-CF8	A351-CN7M
2	Bonnet	A351-CF8M	A351-CF3M	A351-CG8M	A351-CG3M	A351-CF8	A351-CN7M
4	Solid Wedge ≤ 1 1/2"	A351-CF8M	A351-CF3M	A351-CG8M	A351-CG3M	A351-CF8	A351-CN7M
	Flex Wedge ≥ 2"	A351-CF8M	A351-CF3M	A351-CG8M	A351-CG3M	A351-CF8	A351-CN7M
5	Seats	A351 CF8M	A351-CF3M	A351-CG8M	A351-CG3M	A351-CF8	A351-CN7M
6	Stem	A276-316	A276-316L	A276-317	A276-317L	A276-304	B473-N08020
7	Backseat	A351-CF8M	A351-CF3M	A351-CG8M	A351-CG3M	A351-CF8	A351-CN7M
8	Studs 1/2"-12"	A193-B8M	A193-B8M	A193-B8M	A193-B8M	A193-B8	A193-B8M
	Studs ≥ 14"	A193-B8	A193-B8	A193-B8	A193-B8	A193-B8	A193-B8
9	Stud Nuts 1/2"-12"	A194-8M	A194-8M	A194-8M	A194-8M	A194-8	A194-8M
	Stud Nuts ≥ 14"	A194-8	A194-8	A194-8	A194-8	A194-8	A194-8
10	Gasket Cl. 150	Graphite Sheet W/SS					
	Gasket Cl. 300 & Above	Spiral Wound / Graphite + 316					
11	Handwheel 1/2"-12"	ASTM A536	ASTM A536	ASTM A536	ASTM A536	ASTM A536	ASTM A536
	Handwheel ≥ 14"	A216-WCB	A216-WCB	A216-WCB	A216-WCB	A216-WCB	A216-WCB
12	Gland Flange	A351-CF8M	A351-CF3M	A351-CG8M	A351-CG3M	A351-CF8	A351-CN7M
13	Yoke Sleeve	A439 D-2	A439 D-2C	A439 D-2C	A439 D-2C	A439 D-2C	A439 D-2C
14	Handwheel Nut 1/2"-12"	Stainless Steel	Stainless Steel	Stainless Steel	Stainless Steel	Stainless Steel	Stainless Steel
15	Retainer Nut 1/2"-12"	Stainless Steel	Stainless Steel	Stainless Steel	Stainless Steel	Stainless Steel	Stainless Steel
	Retainer Nut ≥ 14"	A576-1020-Zn	A576-1020-Zn	A576-1020-Zn	A576-1020-Zn	A576-1020-Zn	A576-1020-Zn
16	Gland	A276-316	A276-316L	A276-317	A276-317L	A276-304	B473-N08020
18	Eyebolts	A193-B8	A193-B8	A193-B8	A193-B8	A193-B8	A193-B8
19	Eyebolt Pins	A194-8	A194-8	A194-8	A194-8	A194-8	A194-8
20	Eyebolt Nuts	A194-8	A194-8	A194-8	A194-8	A194-8	A194-8
21	Packing	Braided and Die-formed Graphite Rings					
23	Grease Fitting	Steel	Steel	Steel	Steel	Steel	Steel
32	Key 2"-12"	A108	A108	A108	A108	A108	A108
33	Set Pin	Steel	Steel	Steel	Steel	Steel	Steel
34	Washer 1/2"-1 1/2"	304SS	304SS	304SS	304SS	304SS	304SS

NPS 10" - 24"

25	Bearing 16" - 24"	Steel	Steel	Steel	Steel	Steel	Steel
26	Stud	A193 B8M	A193 B8M	A193 B8M	A193 B8M	A193 B8M	A193 B8M
27	Stud Nut	A194 8M	A194 8M	A194 8M	A194 8M	A194 8M	A194 8M
31	Yoke	A351 CF8M	A351 CF8M	A351 CF8M	A351 CF8M	A351 CF8M	A351 CF8M

Class 150 Gate Valves

(37-37 1/2)

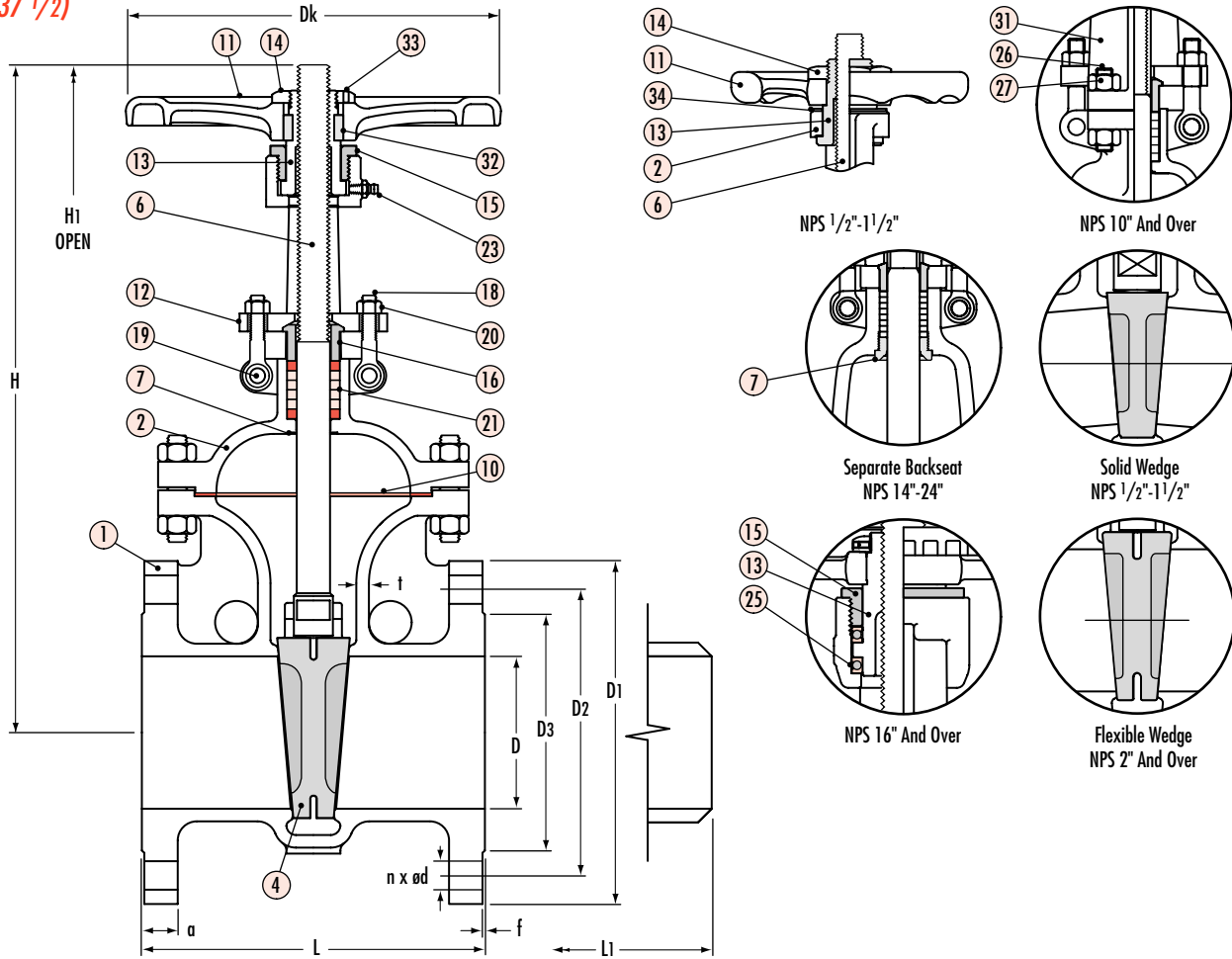

Dimensional Data (in.) and Flow Coefficient (Cv)

End Flange

Size	ØD	ØD1	Bolt Hole			ØD3	a	f	L	L1	H	H1	Dk	t	Wt. Lbs.	Cv
			ØD2	N	Ød											
1/2	0.50	3.50	2.38	4	0.63	1.38	0.31	0.06	4.25	4.25	6.61	7.20	3.94	0.11	5	14
3/4	0.75	3.88	2.75	4	0.63	1.69	0.34	0.06	4.62	4.62	6.65	7.64	3.94	0.12	6	22
1	1.00	4.25	3.12	4	0.63	2.00	0.38	0.06	5.00	5.00	7.01	8.35	3.94	0.16	8	34
1 1/2	1.50	5.00	3.88	4	0.63	2.88	0.50	0.06	6.50	6.50	8.90	10.55	5.51	0.19	16	110
2	2.00	6.00	4.75	4	0.75	3.62	0.56	0.06	7.00	8.50	11.56	13.89	7.87	0.22	30	200
2 1/2	2.50	7.00	5.50	4	0.75	4.12	0.62	0.06	7.50	9.50	13.70	16.54	7.87	0.22	46	260
3	3.00	7.50	6.00	4	0.75	5.00	0.69	0.06	8.00	11.12	15.14	18.50	7.87	0.22	52	460
4	4.00	9.00	7.50	8	0.75	6.19	0.88	0.06	9.00	12.00	17.48	21.76	9.84	0.25	80	825
6	6.00	11.00	9.50	8	0.87	8.50	0.94	0.06	10.50	15.88	22.80	29.06	9.84	0.28	135	2300
8	8.00	13.50	11.75	8	0.87	10.62	1.06	0.06	11.50	16.50	28.76	36.88	13.78	0.31	222	4150
10	10.00	16.00	14.25	12	1.00	12.75	1.12	0.06	13.00	18.00	34.67	45.00	17.72	0.34	224	6700
12	12.00	19.00	17.00	12	1.00	15.00	1.19	0.06	14.00	19.75	40.71	52.99	17.72	0.38	472	9700
14	13.25	21.00	18.75	12	1.12	16.25	1.31	0.06	15.00	22.50	47.80	58.54	17.72	0.41	685	16,277
16	15.25	23.50	21.25	16	1.12	18.50	1.38	0.06	16.00	24.00	54.61	66.89	19.69	0.44	1000	21,562
18	17.25	25.00	22.75	16	1.25	21.00	1.50	0.06	17.00	26.00	61.00	74.80	22.05	0.47	1300	28,715
20	19.25	27.50	25.00	20	1.25	23.00	1.62	0.06	18.00	28.00	66.06	83.46	27.95	0.51	1500	35,760
24	23.25	32.00	29.50	20	1.25	27.25	1.81	0.06	20.00	32.00	78.25	98.50	31.50	0.57	2000	52,165

Class 300 Gate Valves

(23-23 1/2)

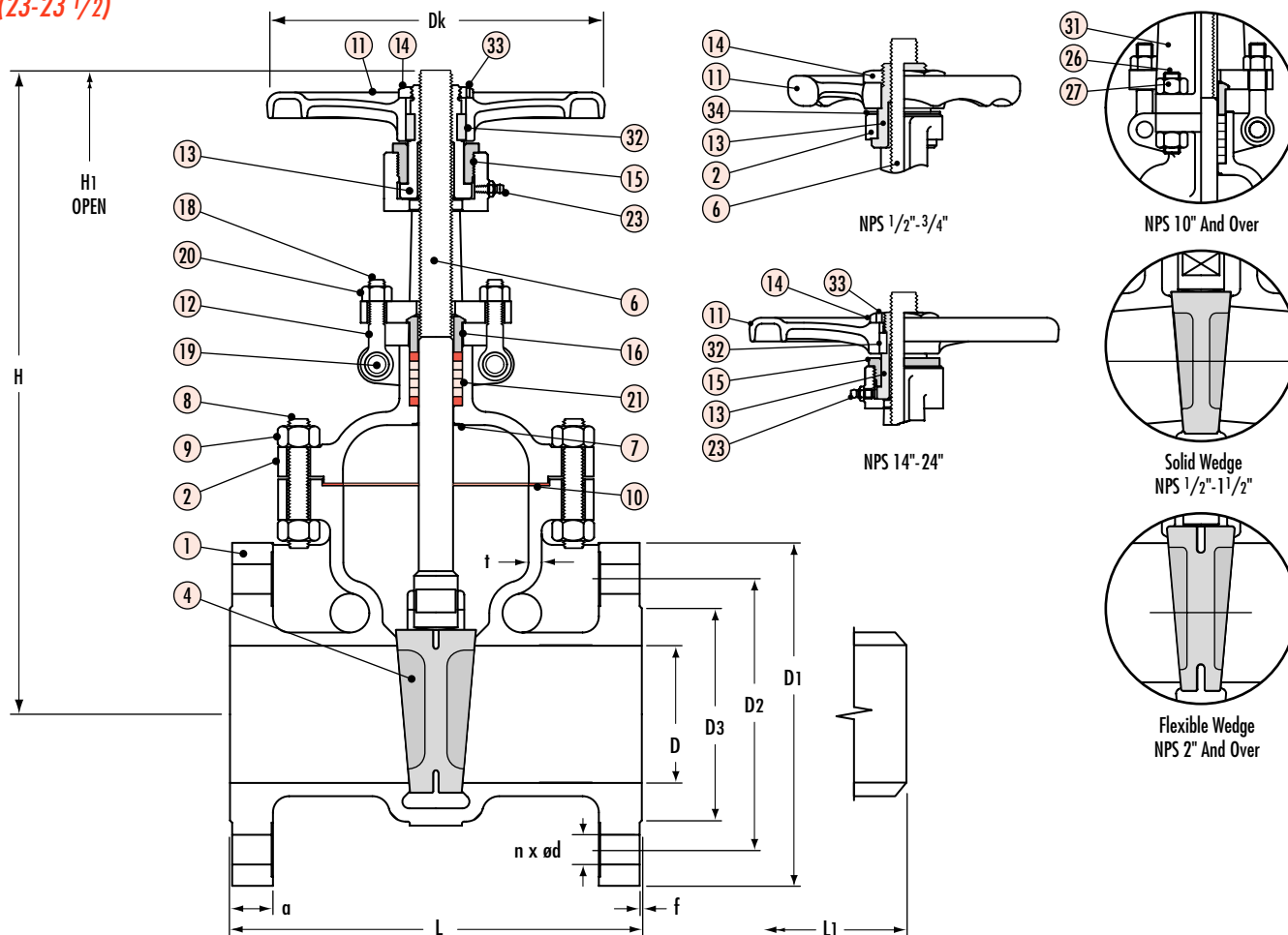

Dimensional Data (in.) and Flow Coefficient (Cv)

End Flange

Size	ØD	ØD1	Bolt Hole			ØD3	α	f	L	L1	H	H1	Dk	t	Wt. Lbs.	Cv
			ØD2	N	Ød											
1/2	0.50	3.75	2.62	4	0.62	1.38	0.50	0.06	5.50	5.50	6.85	7.76	3.94	0.12	7	14
3/4	0.75	4.62	3.25	4	0.75	1.69	0.56	0.06	6.00	6.00	7.13	8.35	3.94	0.15	8	22
1	1.00	4.88	3.50	4	0.75	2.00	0.62	0.06	6.50	6.50	9.61	10.79	7.87	0.19	12	34
1 1/2	1.50	6.12	4.50	4	0.88	2.88	0.75	0.06	7.50	7.50	10.91	12.56	7.87	0.19	24	110
2	2.00	6.50	5.00	8	0.75	3.62	0.81	0.06	8.50	8.50	12.40	14.67	7.87	0.25	44	200
2 1/2	2.50	7.50	5.88	8	0.88	4.12	0.94	0.06	9.50	9.50	13.46	16.22	7.87	0.25	60	260
3	3.00	8.25	6.62	8	0.88	5.00	1.06	0.06	11.12	11.12	15.31	18.70	9.84	0.28	86	460
4	4.00	10.00	7.88	8	0.88	6.19	1.19	0.06	12.00	12.00	19.19	23.19	9.84	0.31	134	825
6	6.00	12.50	10.62	12	0.88	8.50	1.38	0.06	15.88	15.88	23.15	29.53	13.78	0.38	247	2300
8	8.00	15.00	13.00	12	1.00	10.62	1.56	0.06	16.50	16.50	30.57	38.82	17.72	0.44	390	4150
10	10.00	17.50	15.25	16	1.12	12.75	1.81	0.06	18.00	18.00	36.67	47.09	19.69	0.50	630	6700
12	12.00	20.50	17.75	16	1.25	15.00	1.94	0.06	19.75	19.75	42.68	55.16	19.69	0.56	880	9700
14	13.25	23.00	20.25	20	1.25	16.25	2.06	0.06	30.00	30.00	49.00	64.21	22.05	0.62	1500	16,277
16	15.25	25.50	22.50	20	1.38	18.50	2.19	0.06	33.00	33.00	55.79	66.61	24.80	0.69	1750	21,562
18	17.00	28.00	24.75	24	1.38	21.00	2.31	0.06	36.00	36.00	61.00	75.16	27.95	0.75	2200	27,889
20	19.00	30.50	27.00	24	1.38	23.00	2.44	0.06	39.00	39.00	67.68	83.43	31.50	0.81	3000	34,837
24	23.00	36.00	32.00	24	1.62	27.25	2.69	0.06	45.00	45.00	79.92	98.11	35.43	0.94	4200	51,049

Class 600 Gate Valves

(66-66 1/2)

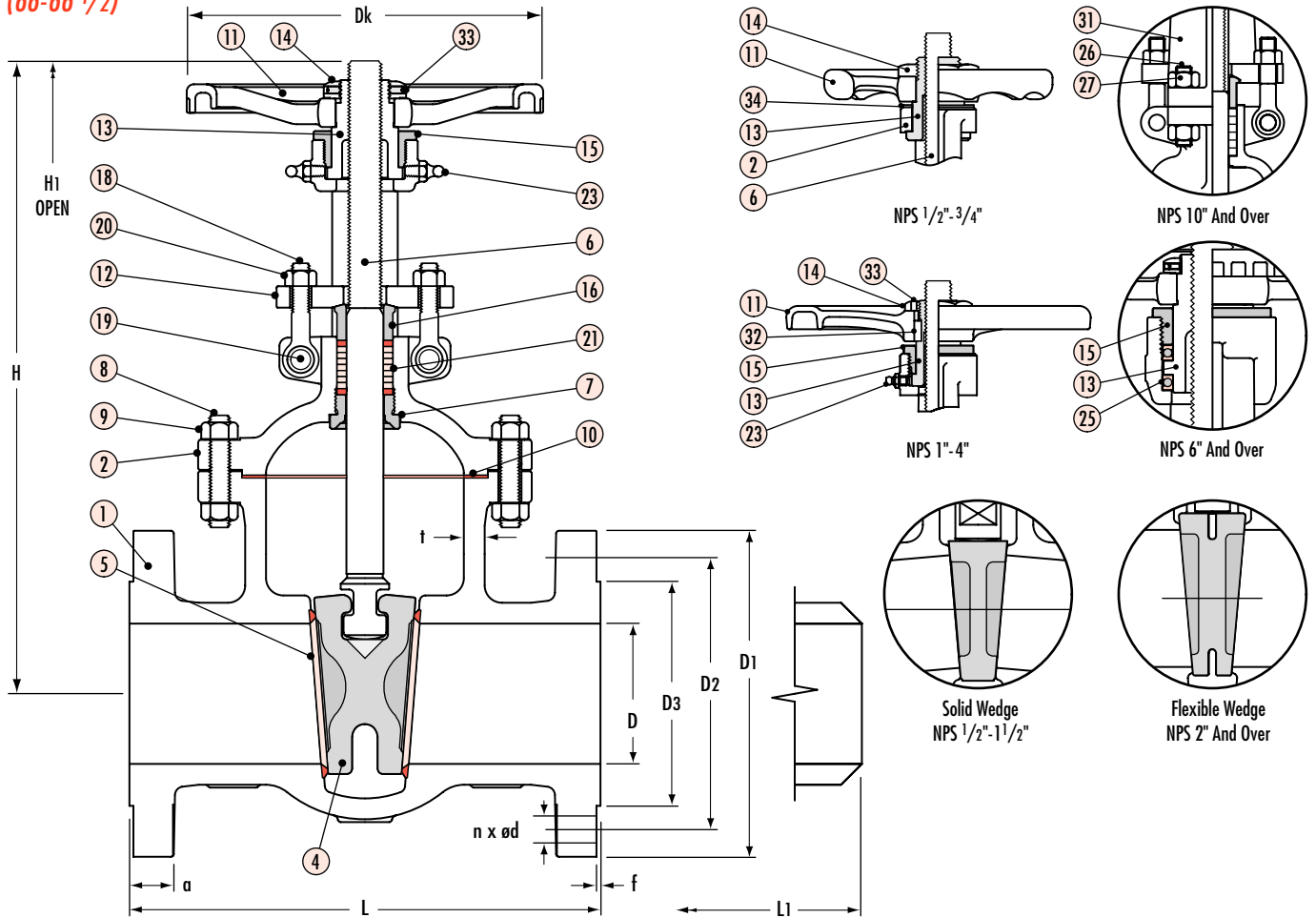

Dimensional Data (in.) and Flow Coefficient (Cv)

End Flange

Size	ØD	ØD1	Bolt Hole			ØD3	α	f	L	L1	H	H1	Dk	t	Wt. Lbs.	Cv
			ØD2	N	Ød											
1/2	0.50	3.75	2.62	4	0.63	1.38	0.56	0.26	6.50	6.50	—	—	—	0.13	8.3	14
3/4	0.75	4.62	3.25	4	0.75	1.69	0.62	0.26	7.50	7.50	—	—	—	0.16	15	22
1	1.00	4.88	3.50	4	0.75	2.00	0.69	0.26	8.50	8.50	—	—	—	0.19	20	34
1 1/2	1.50	6.12	4.50	4	0.88	2.88	0.88	0.26	9.50	9.50	—	—	—	0.22	38	110
2	2.00	6.50	5.00	8	0.75	3.62	1.00	0.26	11.50	11.50	13.23	15.39	7.87	0.25	80	200
2 1/2	2.50	7.50	5.88	8	0.88	4.12	1.12	0.26	13.00	13.00	15.98	18.74	9.84	0.28	105	260
3	3.00	8.25	6.62	8	0.88	5.00	1.25	0.26	14.00	14.00	18.23	21.61	9.84	0.31	110	460
4	4.00	10.75	8.50	8	1.00	6.19	1.50	0.26	17.00	17.00	21.73	25.87	13.78	0.38	220	825
6	6.00	14.00	11.50	12	1.13	8.50	1.88	0.26	22.00	22.00	30.00	36.38	19.69	0.50	650	2300
8	7.87	16.50	13.75	12	1.26	10.62	2.19	0.26	26.00	26.00	35.55	43.86	23.62	0.62	800	4150
10	9.75	20.00	17.00	16	1.38	12.75	2.50	0.26	31.00	31.00	38.58	49.02	29.53	0.75	1400	6700
12	11.75	22.00	19.25	20	1.38	15.00	2.62	0.26	33.00	33.00	48.39	60.87	29.53	0.91	1880	9700
14	12.87	23.75	20.75	20	1.50	16.25	2.75	0.26	35.00	35.00	55.12	64.09	31.50	0.97	2110	15,367
16	14.75	27.00	23.75	20	1.63	18.50	3.00	0.26	39.00	39.00	60.83	71.06	35.43	1.09	2612	20,172
18	16.50	29.25	25.75	20	1.75	21.00	3.25	0.26	43.00	43.00	69.29	78.11	35.43	1.22	3690	26,273
20	18.25	32.00	28.50	24	1.75	23.00	3.50	0.26	47.00	47.00	73.62	79.92	42.99	1.34	4890	32,141
24	22.00	37.00	33.00	24	2.00	27.25	4.00	0.26	55.00	55.00	85.83	82.80	42.99	1.59	7810	46,707

Globe Valves

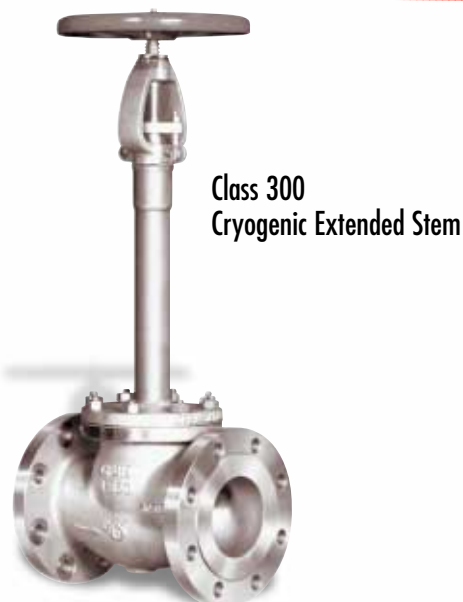

Parts And Materials • Class 150, 300 & 600

Item	Part Name	CF8M	316L	317	317L	304	Alloy 20
1	Body	A351-CF8M	A351-CF3M	A351-CG8M	A351-CG3M	A351-CF8	A351-CN7M
2	Bonnet	A351-CF8M	A351-CF3M	A351-CG8M	A351-CG3M	A351-CF8	A351-CN7M
4	Disc	A351-CF8M	A351-CF3M	A351-CG8M	A351-CG3M	A351-CF8	A351-CN7M
5	Seat	A351-CF8M	A351-CF3M	A351-CG8M	A351-CG3M	A351-CF8	A351-CN7M
6	Stem	A276-316	A276-316L	A276-317	A276-317L	A276-304	B473-N08020
7	Backseat	A351-CF8M	A351-CF3M	A351-CG8M	A351-CG3M	A351-CF8	A351-CN7M
8	Studs	A193-B8M	A193-B8M	A193-B8M	A193-B8M	A193-B8	A193-B8M
9	Stud Nuts	A194-8M	A194-8M	A194-8M	A194-8M	A194-8	A194-8M
10	Gasket Cl. 150	GHE Graphite Sheet W/SS					
	Gasket Cl. 300 & Above	Spiral Wound / Graphite + 316					
11	Stem Lock Nut	A351-CF8M	A351-CF3M	A351-CG8M	A351-CG3M	A351-CF8	A351-CN7M
31	Handwheel	ASTM A536	ASTM A536	ASTM A536	ASTM A536	ASTM A536	ASTM A536
32	Gland Flange	A351-CF8M	A351-CF3M	A351-CG8M	A351-CG3M	A351-CF8	A351-CN7M
33	Yoke Sleeve	A439 D-2C	A439 D-2C	A439 D-2C	A439 D-2C	A439 D-2C	A439 D-2C
34	Handwheel Nut	A194-8	A194-8	A194-8	A194-8	A194-8	A194-8
36	Gland	A276-316	A276-316L	A276-317	A276-317L	A276-304	B473-N08020
38	Eyebolts	A193-B8	A193-B8	A193-B8	A193-B8	A193-B8	A193-B8
39	Eyebolt Pins	A194-8	A194-8	A194-8	A194-8	A194-8	A194-8
40	Eyebolt Nuts	A194-8	A194-8	A194-8	A194-8	A194-8	A194-8
41	Packing	Braided and Die-formed Graphite Rings					
52	Washer	304SS	304SS	304SS	304SS	304SS	304SS

Class 150 Globe Valves
(133-133 1/2)

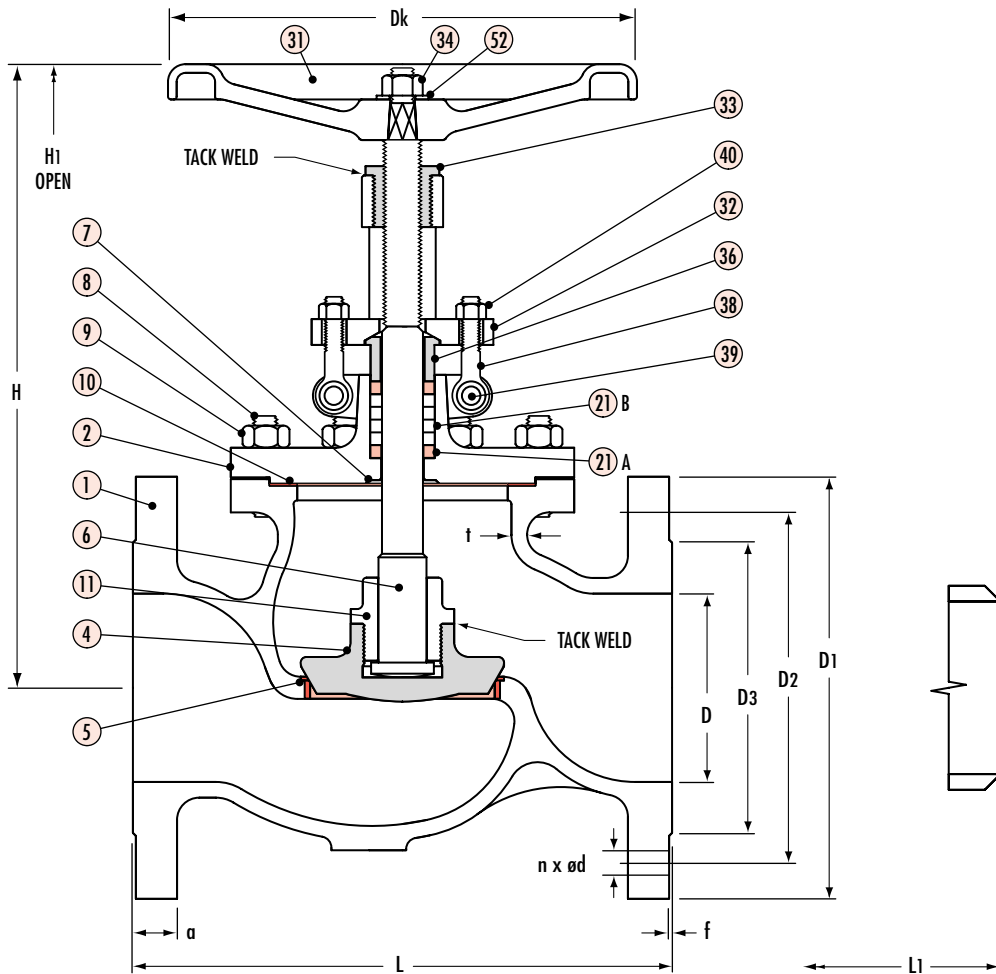

Dimensional Data (in.) and Flow Coefficient (Cv)

End Flange

Size	ØD	ØD1	Bolt Hole			ØD3	α	f	L	L1	H	H1	Dk	t	Wt. Lbs.	Cv
			ØD2	N	Ød											
1/2	0.50	3.50	2.38	4	0.62	1.38	0.31	0.06	4.25	4.25	6.10	6.72	3.94	0.11	5	3
3/4	0.75	3.88	2.75	4	0.62	1.69	0.34	0.06	4.62	4.62	6.31	6.92	3.94	0.12	6.5	4
1	1.00	4.25	3.12	4	0.62	2.00	0.38	0.06	5.00	5.00	6.38	6.96	3.94	0.16	10	6
1 1/2	1.50	5.00	3.88	4	0.62	2.88	0.50	0.06	6.50	6.50	7.75	8.54	5.51	0.19	20	14
2	2.00	6.00	4.75	4	0.75	3.62	0.56	0.06	8.00	8.00	9.02	10.26	7.87	0.22	27	33
2 1/2	2.50	7.00	5.50	4	0.75	4.12	0.62	0.06	8.50	8.50	10.35	11.63	7.87	0.22	40	65
3	3.00	7.50	6.00	4	0.75	5.00	0.69	0.06	9.50	9.50	11.10	12.62	7.87	0.22	50	100
4	4.00	9.00	7.50	8	0.75	6.19	0.88	0.06	11.50	11.50	13.30	14.93	9.84	0.25	83	170
6	6.00	11.00	9.50	8	0.88	8.50	0.94	0.06	16.00	16.00	15.41	16.41	9.84	0.28	154	375
8	8.00	13.50	11.75	8	0.88	10.62	1.06	0.06	19.50	19.50	19.26	23.25	13.78	0.31	295	710
10	10.00	16.00	14.25	12	1.00	12.75	1.12	0.06	24.50	24.50	23.27	27.72	17.72	0.34	490	1000
12	12.00	19.00	17.00	12	1.00	15.00	1.19	0.06	27.50	27.50	26.14	31.69	17.72	0.38	715	1720

Class 300 Globe Valves
(141-141 1/2)

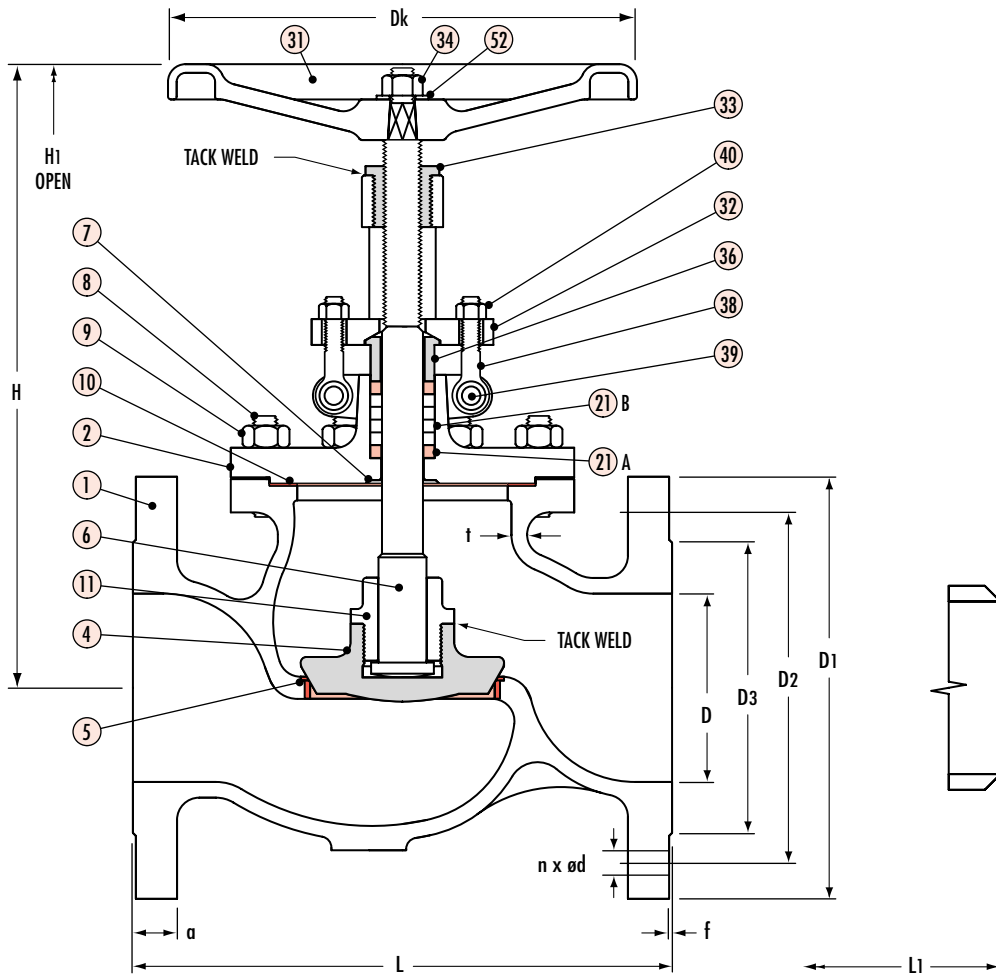

Dimensional Data (in.) and Flow Coefficient (Cv)

End Flange

Size	ØD	ØD1	Bolt Hole			ØD3	α	f	L	L1	H	H1	Dk	t	Wt. Lbs.	Cv
			ØD2	N	Ød											
1/2	0.50	3.75	2.62	4	0.63	1.38	0.50	0.06	6.00	6.00	6.85	7.36	3.94	0.12	6.5	3
3/4	0.75	4.62	3.25	4	0.75	1.69	0.56	0.06	7.00	7.00	6.85	7.36	3.94	0.15	11.3	4
1	1.00	4.88	3.50	4	0.75	2.00	0.62	0.06	8.00	8.00	7.56	8.03	5.51	0.19	13.1	6
1 1/2	1.50	6.12	4.50	4	0.87	2.88	0.75	0.06	9.00	9.00	8.90	9.61	6.30	0.19	26	14
2	2.00	6.50	5.00	8	0.75	3.62	0.81	0.06	10.50	10.50	10.33	11.28	7.87	0.25	45	33
2 1/2	2.50	7.50	5.88	8	0.87	4.12	0.94	0.06	11.50	11.50	11.46	12.72	7.87	0.25	70	65
3	3.00	8.25	6.62	8	0.87	5.00	1.06	0.06	12.50	12.50	12.57	13.85	9.84	0.28	87	100
4	4.00	10.00	7.88	8	0.87	6.19	1.19	0.06	14.00	14.00	14.75	16.29	9.84	0.31	130	170
6	6.00	12.50	10.62	12	0.87	8.50	1.38	0.06	17.50	17.50	19.25	21.63	13.78	0.38	252	375
8	8.00	15.00	13.00	12	0.98	10.62	1.56	0.06	22.00	22.00	23.50	26.96	17.72	0.44	495	710
10	10.00	17.50	15.25	16	1.13	12.75	1.81	0.06	24.50	24.50	26.02	30.47	23.62	0.50	810	1000
12	12.00	20.50	17.75	16	1.26	15.00	1.94	0.06	28.00	28.00	29.65	35.59	23.62	0.56	1060	1720

Class 600 Globe Valves
(161-161 1/2)

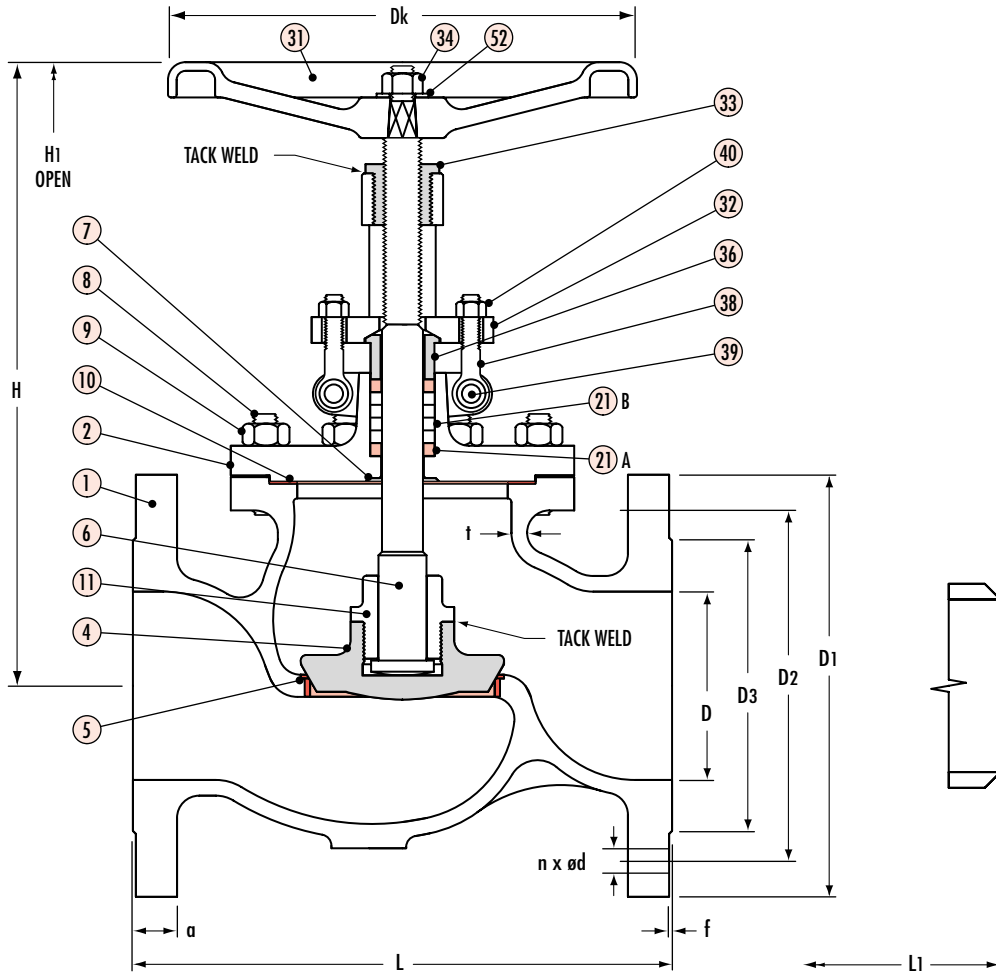

Dimensional Data (in.) and Flow Coefficient (Cv)

End Flange

Size	ØD	ØD1	Bolt Hole			ØD3	α	f	L	L1	H	H1	Dk	t	Wt. Lbs.	Cv
			ØD2	N	Ød											
1/2	0.50	3.75	2.62	4	0.63	1.38	0.56	0.26	6.50	6.50	—	—	—	0.13	8.5	3
3/4	0.75	4.62	3.25	4	0.75	1.69	0.62	0.26	7.50	7.50	—	—	—	0.16	13	4
1	1.00	4.88	3.50	4	0.75	2.00	0.69	0.26	8.50	8.50	—	—	—	0.19	17	6
1 1/2	1.50	6.12	4.50	4	0.88	2.88	0.88	0.26	9.50	9.50	—	—	—	0.22	36	14
2	2.00	6.50	5.00	8	0.75	3.62	1.00	0.26	11.50	11.50	10.33	15.43	7.87	0.25	58	33
2 1/2	2.50	7.50	5.88	8	0.87	4.12	1.12	0.26	13.00	13.00	11.46	17.00	7.87	0.28	140	65
3	3.00	8.25	6.62	8	0.87	5.00	1.25	0.26	14.00	14.00	12.57	18.82	9.84	0.31	180	100
4	4.00	10.75	8.50	8	1.00	6.19	1.50	0.26	17.00	17.00	14.75	20.91	9.84	0.38	260	170
6	6.00	14.00	11.50	12	1.13	8.50	1.88	0.26	22.00	22.00	19.25	26.57	13.78	0.50	610	375
8	7.88	16.50	13.75	12	1.25	10.62	2.19	0.26	26.00	26.00	23.50	28.39	17.72	0.62	760	710
10	9.75	20.00	17.00	16	1.38	12.75	2.50	0.26	31.00	31.00	26.02	38.27	23.62	0.75	890	1000
12	11.75	22.00	19.25	20	1.38	15.00	2.62	0.26	33.00	33.00	29.65	42.28	23.62	0.91	1290	1720

Swing Check Valves

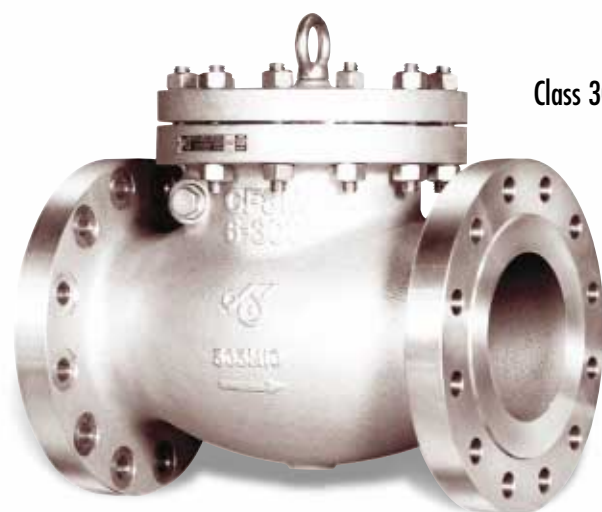

Class 300

Parts And Materials • Class 150, 300 & 600

Item	Part Name	CF8M	316L	317	317L	304	Alloy 20
1	Body	A351-CF8M	A351-CF3M	A351-CG8M	A351-CG3M	A351-CF8	A351-CN7M
2	Cover	A351-CF8M	A351-CF3M	A351-CG8M	A351-CG3M	A351-CF8	A351-CN7M
3	Disc	A351-CF8M	A351-CF3M	A351-CG8M	A351-CG3M	A351-CF8	A351-CN7M
4	Arm	A351-CF8M	A351-CF3M	A351-CG8M	A351-CG3M	A351-CF8	A351-CN7M
5	Seat	A351-CF8M	A351-CF3M	A351-CG8M	A351-CG3M	A351-CF8	A351-CN7M
6	Arm Pin	A276-316	A276-316L	A276-317	A276-317L	A276-304	B473-N08020
8	Disc Nut	A276-316	A276-316L	A276-317	A276-317L	A276-304	B473-N08020
10	Gasket Cl. 150	Graphite Sheet W/ GHE					
	Gasket Cl. 300 & above	Spiral Wound / Graphite + 316					
11	Studs	A193-B8M	A193-B8M	A193-B8M	A193-B8M	A193-B8	A193-B8M
12	Stud Nuts	A194-8M	A194-8M	A194-8M	A194-8M	A194-8	A194-8M
13	Side Plug	A276-316	A276-316L	A276-317	A276-317L	A276-304	B473-N08020
14	Split Pin	A276-316	A276-316L	A276-317	A276-317L	A276-304	B473-N08020
16	Side Plug Gasket	Stainless Steel	Stainless Steel	Stainless Steel	Stainless Steel	Stainless Steel	Stainless Steel
18	Disc Washer	Stainless Steel	Stainless Steel	Stainless Steel	Stainless Steel	Stainless Steel	Stainless Steel
20	Eyebolt	Steel	Steel	Steel	Steel	Steel	Steel

Class 150 Swing Check Valves (137-137 1/2)

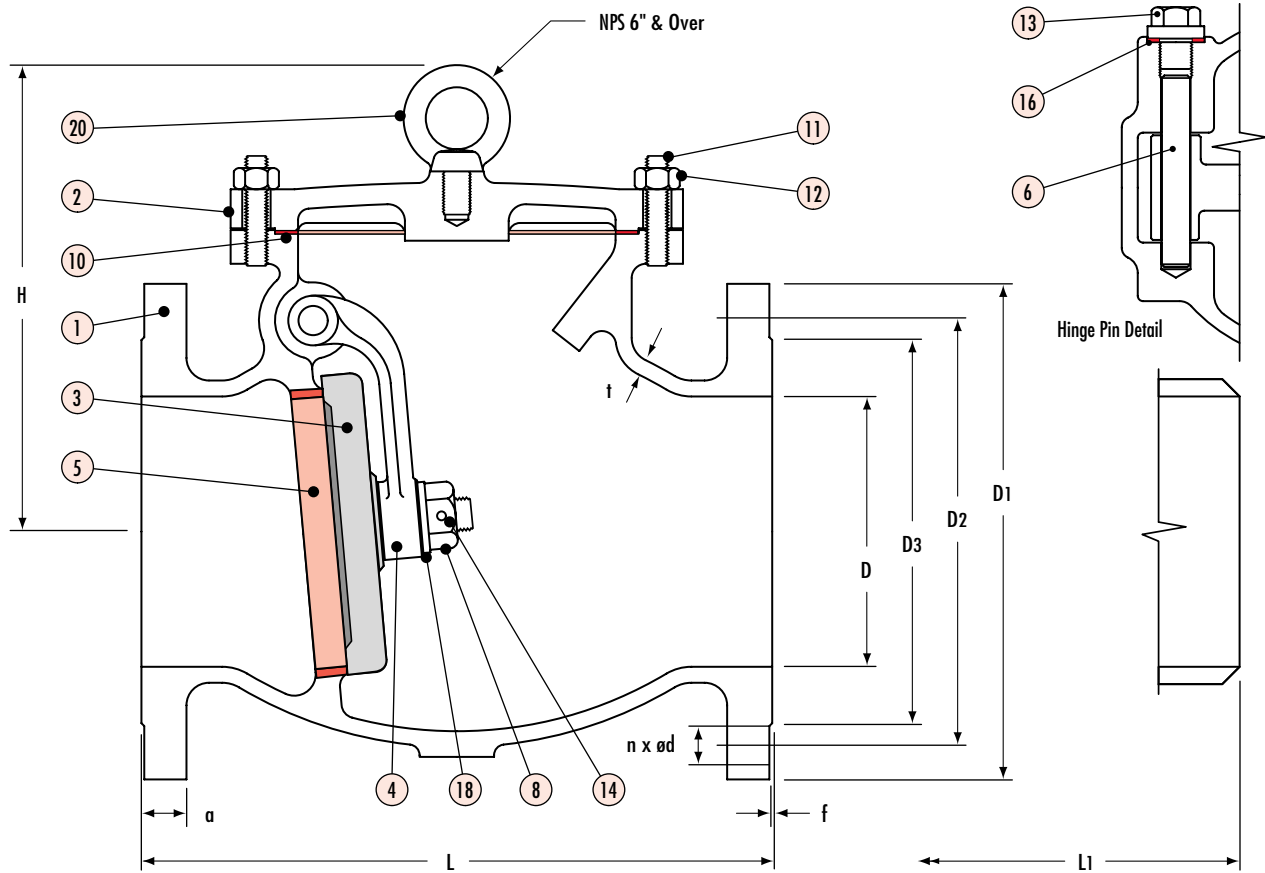

Dimensional Data (in.) and Flow Coefficient (Cv)

Size	End Flange													Wt. Lbs.	Cv
	ØD	ØD1	Bolt Hole			ØD3	a	f	L	L1	H	t			
			ØD2	N	Ød										
1/2	0.50	3.50	2.38	4	0.63	1.38	0.31	0.06	4.25	4.25	2.72	0.11	4	9	
3/4	0.75	3.88	2.75	4	0.63	1.69	0.34	0.06	4.62	4.62	2.95	0.12	6	10	
1	1.00	4.25	3.12	4	0.63	2.00	0.38	0.06	5.00	5.00	3.41	0.16	8	22	
1 1/2	1.50	5.00	3.88	4	0.63	2.88	0.50	0.06	6.50	6.50	3.74	0.19	15	55	
2	2.00	6.00	4.75	4	0.75	3.62	0.56	0.06	8.00	8.00	4.59	0.22	21	82	
2 1/2	2.50	7.00	5.50	4	0.75	4.12	0.62	0.06	8.50	8.50	5.26	0.22	30	170	
3	3.00	7.50	6.00	4	0.75	5.00	0.69	0.06	9.50	9.50	5.89	0.22	43	170	
4	4.00	9.00	7.50	8	0.75	6.19	0.88	0.06	11.50	11.50	6.69	0.25	68	295	
6	6.00	11.00	9.50	8	0.87	8.50	0.94	0.06	16.00	16.00	10.35	0.28	128	830	
8	8.00	13.50	11.75	8	0.87	10.62	1.06	0.06	19.50	19.50	12.19	0.31	226	1525	
10	10.00	16.00	14.25	12	1.00	12.75	1.12	0.06	24.50	24.50	14.39	0.34	317	2400	
12	12.00	19.00	17.00	12	1.00	15.00	1.19	0.06	27.50	27.50	16.13	0.38	530	3500	

Class 300 Swing Check Valves (149-149 1/2)

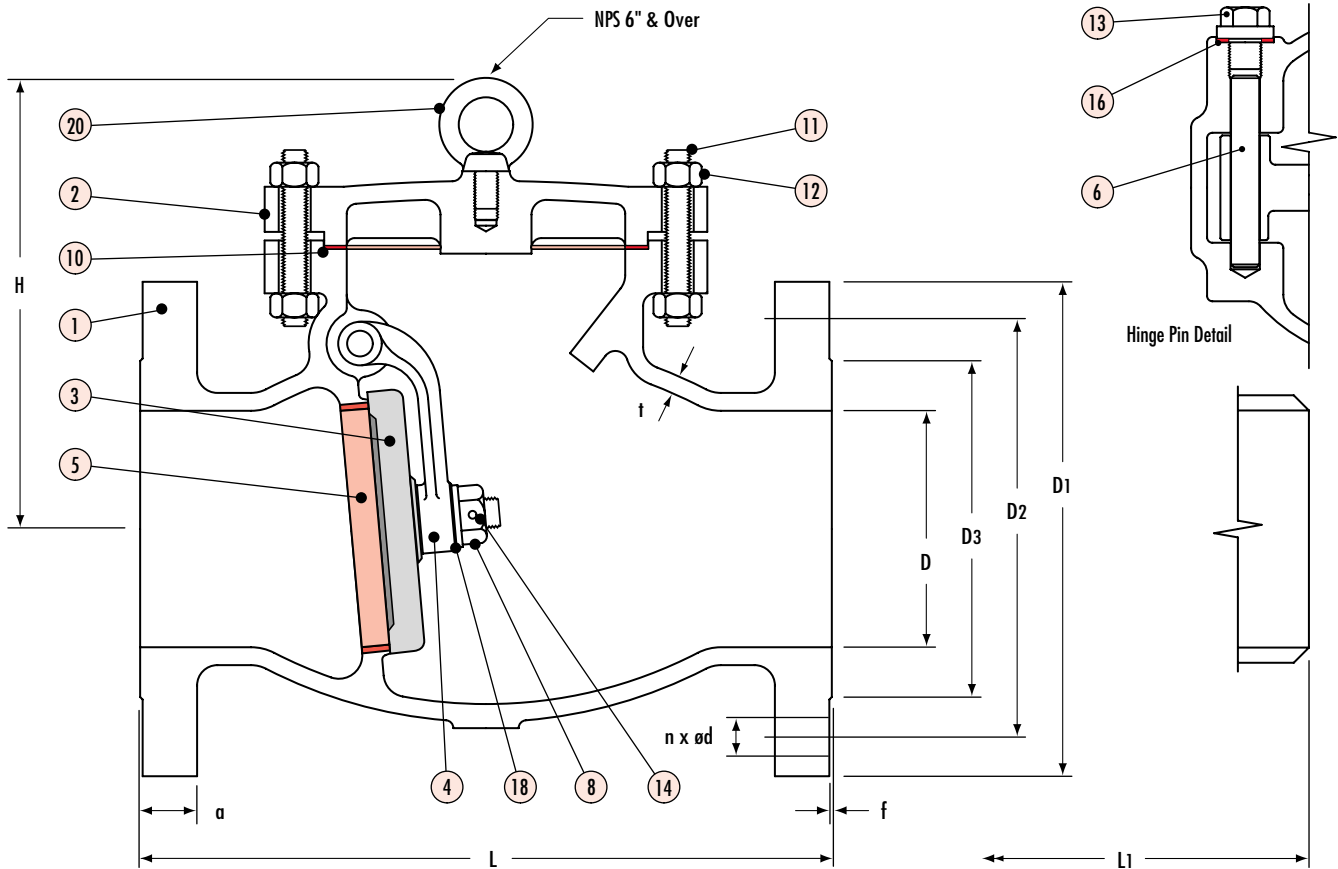

Dimensional Data (in.) and Flow Coefficient (Cv)

Size	End Flange													Wt. Lbs.	Cv
	ØD	ØD1	Bolt Hole			ØD3	a	f	L	L1	H	t			
			ØD2	N	Ød										
1/2	0.50	3.75	2.62	4	0.63	1.38	0.50	0.06	6.00	6.00	3.11	0.12	12	9	
3/4	0.75	4.62	3.25	4	0.75	1.69	0.56	0.06	7.00	7.00	3.35	0.15	16	10	
1	1.00	4.88	3.50	4	0.75	2.00	0.62	0.06	8.50	8.50	3.62	0.19	29	22	
1 1/2	1.50	6.12	4.50	4	0.87	2.88	0.75	0.06	9.50	9.50	4.17	0.19	30	55	
2	2.00	6.50	5.00	8	0.75	3.62	0.81	0.06	10.50	10.50	5.61	0.25	42	82	
2 1/2	2.50	7.50	5.88	8	0.87	4.12	0.94	0.06	11.50	11.50	6.10	0.25	62	170	
3	3.00	8.25	6.62	8	0.87	5.00	1.06	0.06	12.50	12.50	7.01	0.28	80	170	
4	4.00	10.00	7.88	8	0.87	6.19	1.19	0.06	14.00	14.00	7.82	0.31	118	295	
6	6.00	12.50	10.62	12	0.87	8.50	1.38	0.06	17.50	17.50	11.42	0.38	212	830	
8	8.00	15.00	13.00	12	0.98	10.62	1.56	0.06	21.00	21.00	13.70	0.44	330	1525	
10	10.00	17.50	15.25	16	1.13	12.75	1.81	0.06	24.50	24.50	15.93	0.50	528	2400	
12	12.00	20.50	17.75	16	1.26	15.00	1.94	0.06	28.00	28.00	18.41	0.56	802	3500	

Class 600 Swing Check Valves (165-165 1/2)

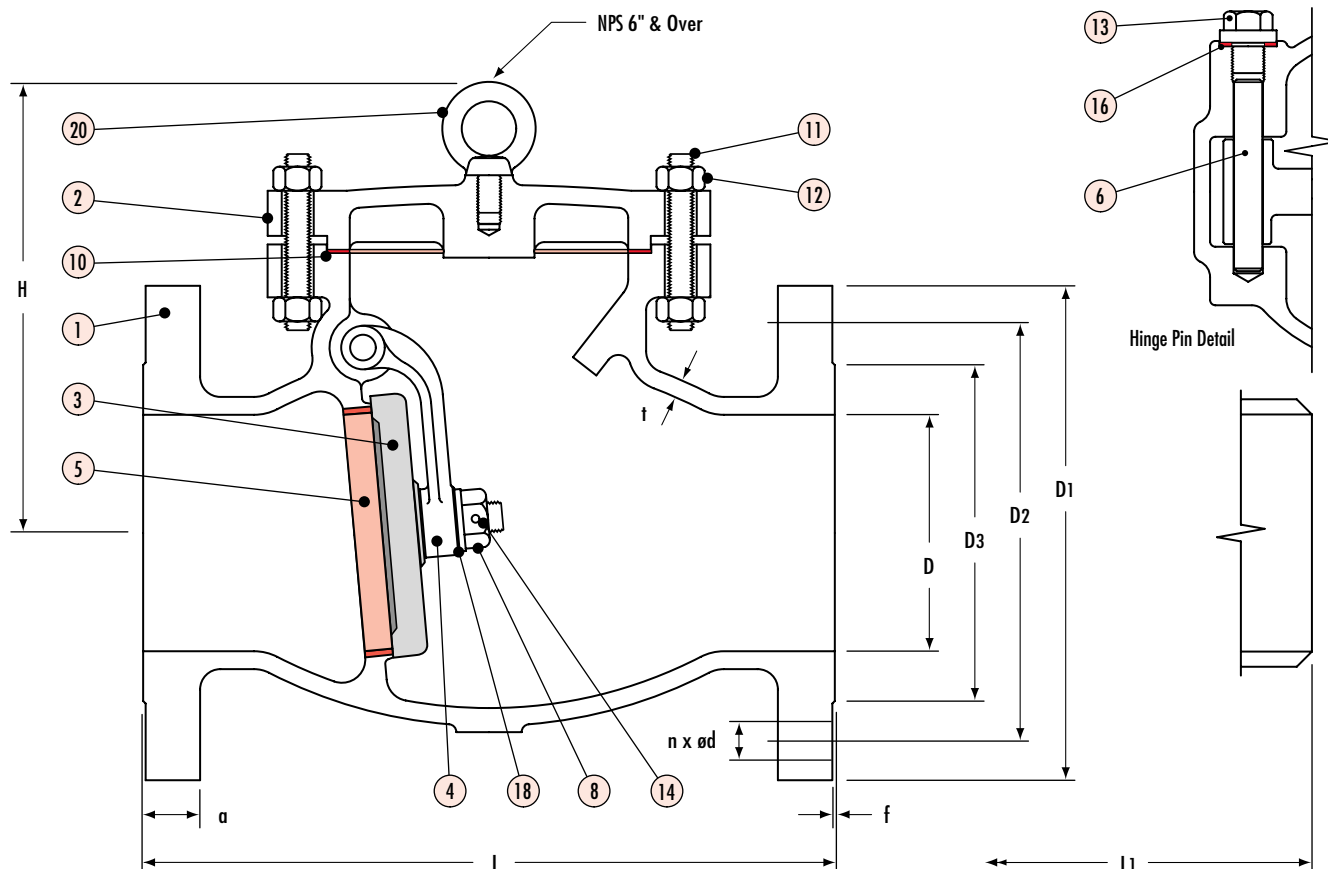

Dimensional Data (in.) and Flow Coefficient (C_v)

Size	End Flange													Wt. Lbs.	C _v
	ØD	ØD1	Bolt Hole			ØD3	a	f	L	L1	H	t			
			ØD2	N	Ød										
1/2	0.50	3.75	2.62	4	0.63	1.38	0.56	0.26	6.50	6.50	—	0.13	10	9	
3/4	0.75	4.62	3.25	4	0.75	1.69	0.62	0.26	7.50	7.50	—	0.16	18	10	
1	1.00	4.88	3.50	4	0.75	2.00	0.69	0.26	8.50	8.50	—	0.19	24	22	
1 1/2	1.50	6.12	4.50	4	0.87	2.88	0.88	0.26	9.50	9.50	—	0.22	40	55	
2	2.00	6.50	5.00	8	0.75	3.62	1.00	0.26	11.50	11.50	7.36	0.25	53	82	
2 1/2	2.50	7.50	5.88	8	0.87	4.12	1.12	0.26	13.00	13.00	7.87	0.28	69	170	
3	3.00	8.25	6.62	8	0.87	5.00	1.25	0.26	14.00	14.00	8.27	0.31	88	170	
4	4.00	10.75	8.50	8	1.00	6.19	1.50	0.26	17.00	17.00	10.08	0.38	170	295	
6	6.00	14.00	11.50	12	1.13	8.50	1.88	0.26	22.00	22.00	12.95	0.50	400	830	
8	7.87	16.50	13.75	12	1.25	10.62	2.19	0.26	26.00	26.00	14.33	0.62	610	1525	
10	9.75	20.00	17.00	16	1.38	12.75	2.50	0.26	31.00	31.00	18.27	0.75	995	2400	
12	11.75	22.00	19.25	20	1.38	15.00	2.62	0.26	33.00	33.00	19.13	0.91	1310	3500	

Stainless Steel Valves Pressure Temperature Ratings

Pressure temperature ratings are based on ASME B16.34 (1996 edition).

The temperatures shown are that of the pressure-containing shell, which is considered to be the same temperature as that of the fluid flowing within it.

Special consideration should be given to such items as trim, bonnet gasket material, and packing to assure that the rating is merited in all respects.

Maximum Allowable Non-Shock Pressure (PSIG)

Service Temperature	CF8M CG8M CF3M	CF8	CF8M CG8M CF3M	CF8	CF8M CG8M CF3M	CF8	CF8M CG8M CF3M	CF8	CF8M CG8M CF3M	CF8
Temperature °F	Class 150		Class 300		Class 600		Class 900		Class 1500	
-20 to 100	275	275	720	720	1440	1440	2160	2160	3600	3600
200	235	230	620	600	1240	1200	1860	1800	3095	3000
300	215	205	560	540	1120	1080	1680	1620	2795	2700
400	195	190	515	495	1025	995	1540	1490	2570	2485
500	170	170	480	465	955	930	1435	1395	2390	2330
600	140	140	450	435	900	875	1355	1310	2255	2185
650	125	125	445	430	890	860	1330	1290	2220	2150
700	110	110	430	425	870	850	1305	1275	2170	2125
750	95	95	425	415	855	830	1280	1245	2135	2075
800	80	80	420	405	845	805	1265	1210	2110	2015
850	65	65	420	395	835	790	1255	1190	2090	1980
900	50	50	415	390	830	780	1245	1165	2075	1945
950	35	35	385	380	775	765	1160	1145	1930	1910
1000	20	20	350	320	700	640	1050	965	1750	1605
1050	20 (1)	20 (1)	345	310	685	615	1030	925	1720	1545
1100	20 (1)	20 (1)	305	255	610	515	915	770	1525	1285
1150	20 (1)	20 (1)	235	200	475	400	710	595	1185	995
1200	20 (1)	20 (1)	185	155	370	310	555	465	925	770
1250	20 (1)	20 (1)	145	115	295	225	440	340	735	565
1300	20 (1)	20 (1)	115	85	235	170	350	255	585	430
1350	20 (1)	20 (1)	95	60	190	125	290	185	480	310
1400	20 (1)	20 (1)	75	50	150	95	225	145	380	240
1450	20 (1)	15 (1)	60	35	115	70	175	105	290	170
1500	20 (1)	10 (1)	40	25	85	55	125	80	205	135
Hydrostatic Shell Test Press.	450		1125		2250		3350		5575	
Valve Closure	Liquid	320		825		1650		2450		4080
Test Pressure	Air	80		80		80		80		80

Note: (1) For welding end valves only. Flanged end ratings terminate at 1000°F.