

Tuflin® Sleeved Plug Valves

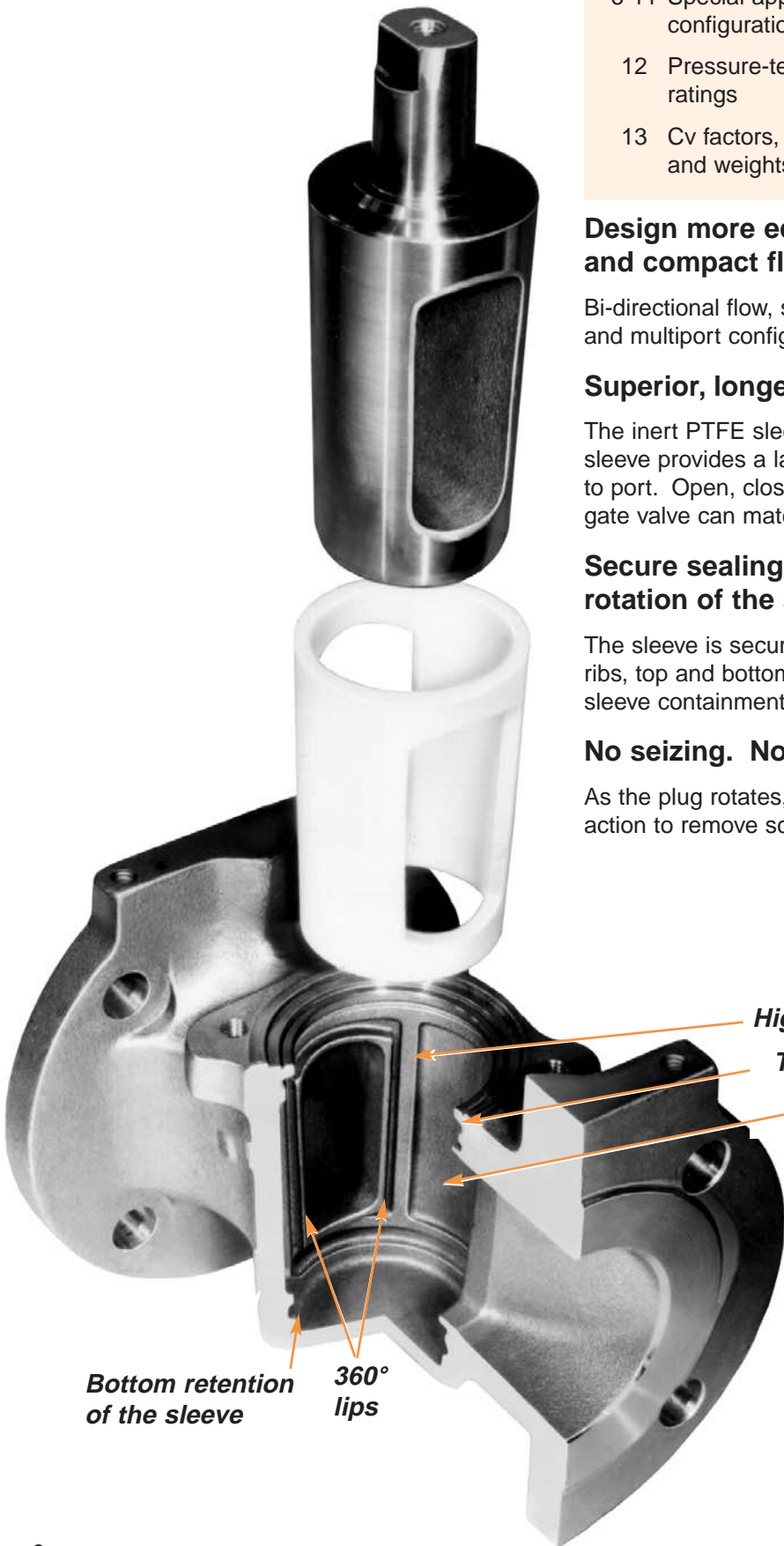

Page / Contents	Page / Contents
2-4 Unique and patented features	16 Manual operators and actuators
5 Multiport valves	17 Actuator mounting hole configurations
6-11 Special application configurations	18 Quick reference selection table
12 Pressure-temperature ratings	19 How to order
13 Cv factors, dimensions, and weights	



Design more economical, flexible, and compact fluid handling systems.

Bi-directional flow, simple actuation, lightweight, compact design, and multiport configurations all facilitate improved system design.

Superior, longer-lasting in-line sealing.

The inert PTFE sleeve completely surrounds the plug. The sleeve provides a large, circumferential sealing surface from port to port. Open, closed, or rotating, the seal is assured. No ball or gate valve can match this sealing power.

Secure sealing with no cold-flow, deformation, or rotation of the sleeve.

The sleeve is securely nestled in the valve body. High pressure ribs, top and bottom retention, and 360° port lips all assure sleeve containment.

No seizing. No sticking.

As the plug rotates, the 360° port lips provide a self-cleaning action to remove scaling and adhering media.

High Pressure sealing ribs

Top retention of sleeve

Sleeve relief area

Bottom retention of the sleeve

360° lips

No cavities. No contamination.

There are no body cavities where flow media can accumulate and contaminate future processing. This cavity-free design also prevents sticking.

**Eliminate unscheduled downtime and maintenance...
plus get greatly extended service life.**

Many processors experience dramatic cost reductions when they switch from ball and gate valves.

A simple turn of the top adjustment bolts keeps the sleeve sealing tightly and the valve in service far longer.

Two independent sealing systems provide double protection against atmospheric leakage.

Turn the page for details about this valve's superior double stem seal.

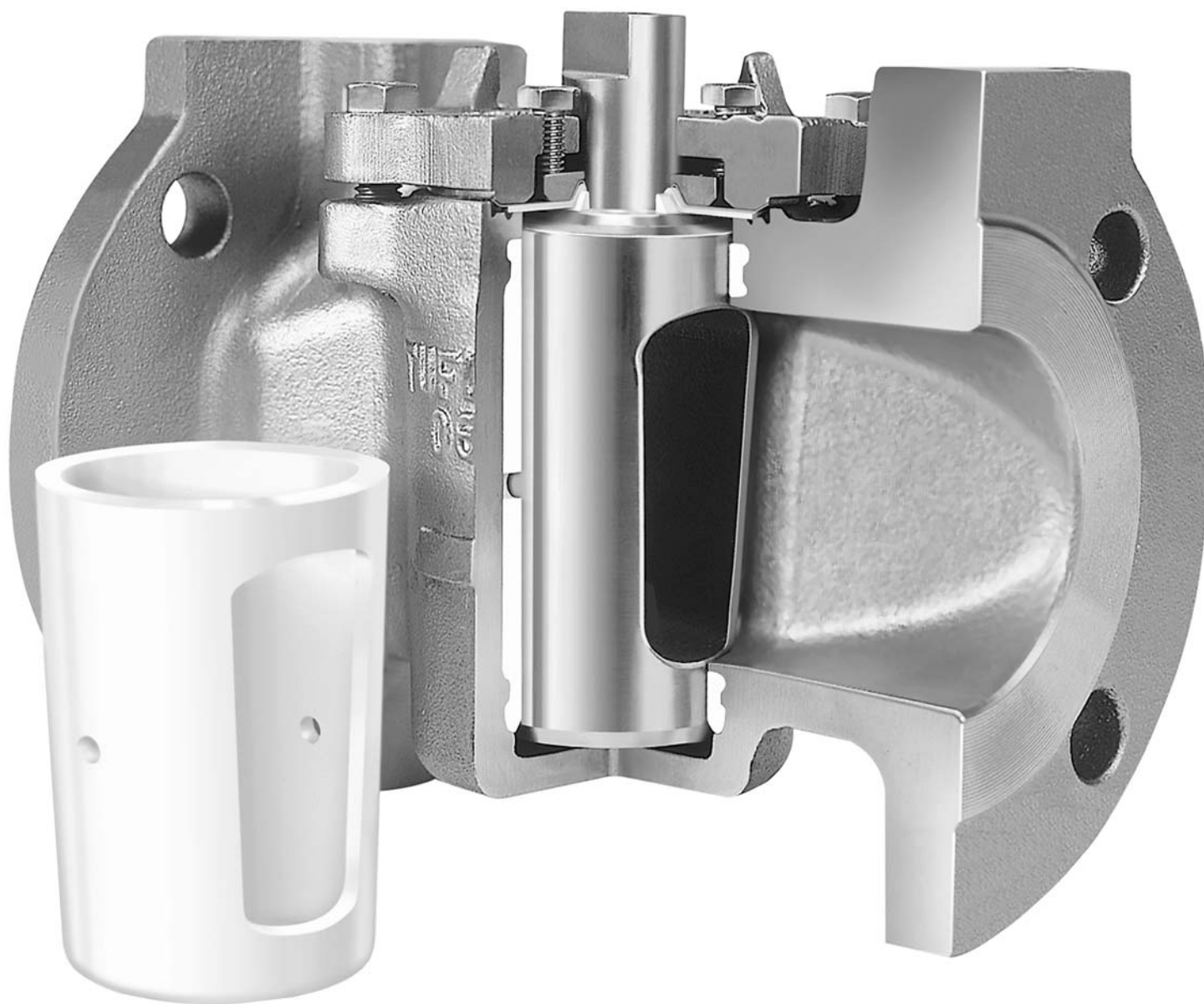

Trouble-free sealing is provided by the large, full-circumferential PTFE sleeve. No ball or gate valve can match this sealing capacity.

The PTFE sleeve has a low coefficient of friction. It acts as a lubricant. Ease of operation is assured, even when the valve is left open or closed for extended periods.

Standard cost and greatly extended service life assure exceptionally low, long-term cost-of-ownership.

The Tufline® sleeved plug valve pays for itself many times over with more up-time and greatly extended service life.

There's a fully adjustable in-line seal and dual stem seal.

Bolts in the top cover provide quick and easy adjustment. Adjust out in-line leakage between shutdowns. Adjust out potential stem leakage.

No ball or gate valve offers this capability.

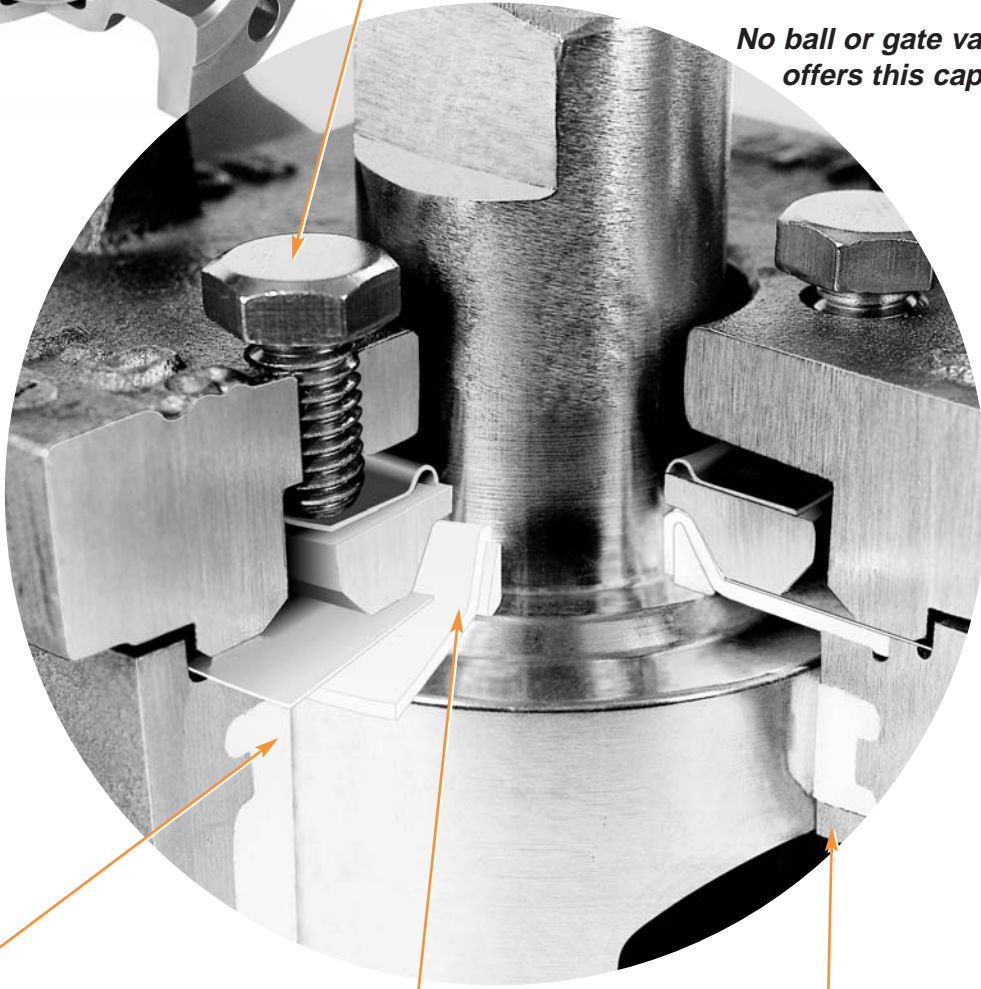
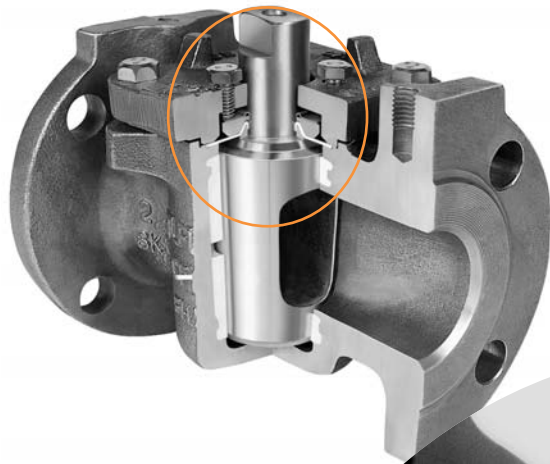

Stem Seal 1.

The primary stem seal is around the circumference of the plug. Flow media is prevented from reaching the stem.

There are two independent environmental seals.
You get double seal protection at no extra cost.

Stem Seal 2.

The secondary backup seal system provides a wide comprehensive backup seal along the top edge of the plug and the stem.

Unmatched stem sealing.

The Tufline standard dual stem seal is clearly superior to those of gate valves, ball valves, other plug valves, and many expensive valves with extended auxiliary packing.

360° lips.

Port defining lips were developed and patented by Tufline. The lips surround the ports.

The lips improve valve performance and extend service life by:

- Preventing sleeve cold flow and deformation.
- Eliminating sleeve rotation.
- Breaking up and removing adhering, scaly deposits from the outer surface of the plug as it rotates.

Multiport valves

Tufline Multiport Sleeved Plug Valves bring economy and more compact system design to thousands of applications.

Bi-directional flow for more flexibility.

In the diagrams the color indicates the path of fluid flow. Bi-directional flow permits more system design options.



3-way arrangements.

Only the Type A plug will shut off the flow. With the Type AX, C, and D plugs, there is always flow between the bottom port and one of the side ports.



4-way and 5-way valves.

For optimum system flexibility 4-way and 5-way multiported valves are available.

		0° position	90° position	180° position
Type A				
Type AX				
Type C				
Type C pos. 1&2 only				
Type C pos. 2&3 only				
Type D				
Type D pos. 1&2 only				
Type D pos. 2&3 only				

Fire Tested Valves

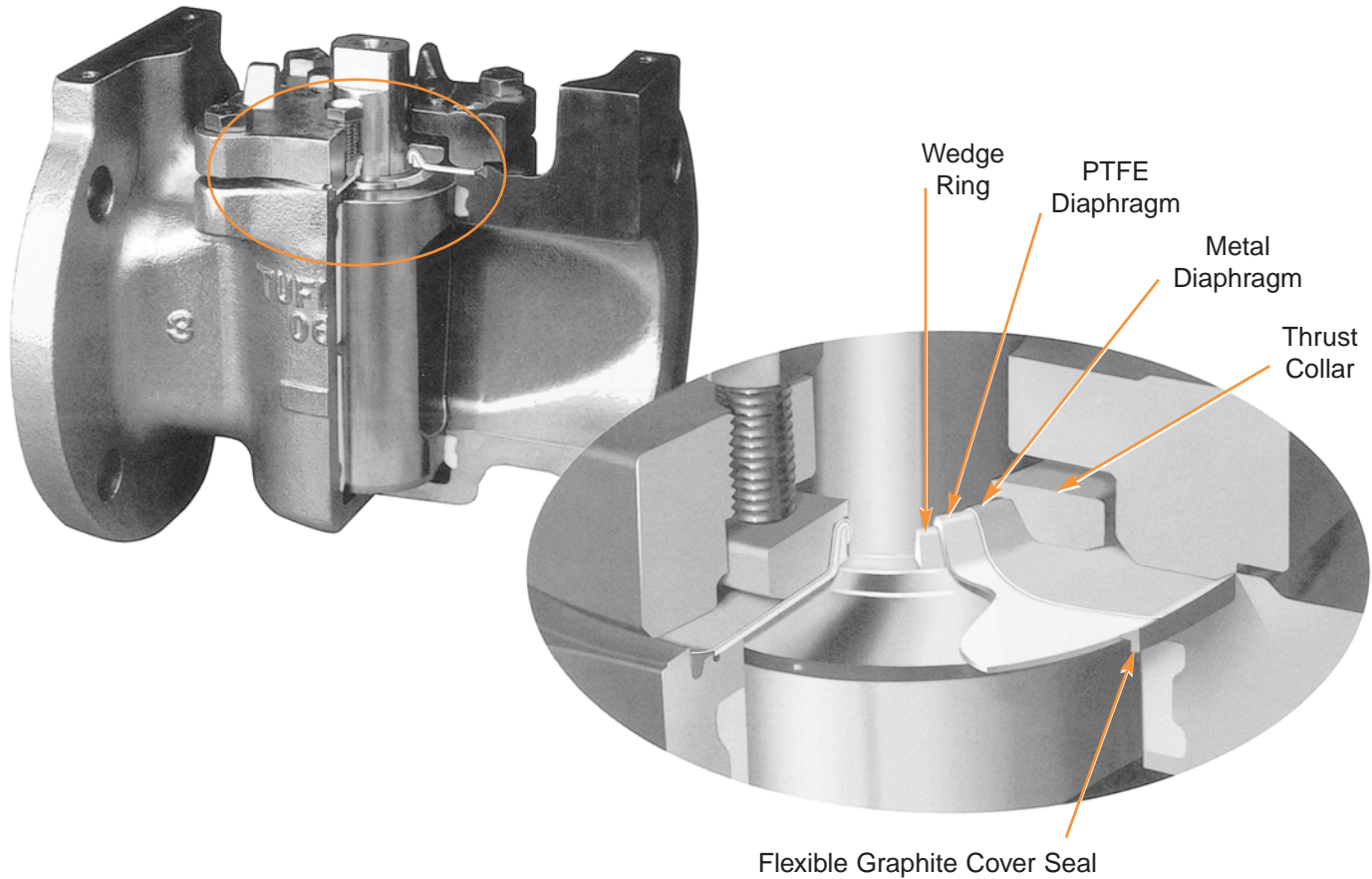

API-607 Standards.

Tufline Fire Tested Sleeved Plug Valves have been tested in accordance with API-607 - Fourth Edition - Section 4.2 - Specifications For External Leakage. These valves exceed the sealing requirements specified in those standards. A tight external seal was maintained even after the PTFE sleeve and sealing parts were totally destroyed by fire.

Fire tested stem seal.

A metal diaphragm overlays the PTFE diaphragm. If the PTFE diaphragm and wedge ring are destroyed by fire, the metal diaphragm maintains the seal.

Fire tested cover seal.

In the standard valve, if the PTFE sleeve and diaphragm are destroyed by fire, leakage would occur at the cover joint. The flexible graphite cover seal prevents this. It is fitted into a machined counter-bore in the valve body. The cover bolts compress the graphite ring between the valve body and cover. Even if fire occurs, this seal is maintained.

Vented plug.

In fire tested valves, the plug is vented on the upstream side. This relieves the expansive pressure caused by the heat of the fire. Valves with vented plugs are unidirectional. An arrow stamped on the valve body indicates the flow direction.

Sizes: ½" - 6".

For larger sizes use the Tertiary Top Seal shown on the next page.

Configurations: 2, 3, 4, and 5-way.
Also partially and fully jacketed.

End connections:
Screwed, flanged, weld.

Pressure ratings:
ANSI 150, 300, and 600.

Tertiary Top Seal Valves

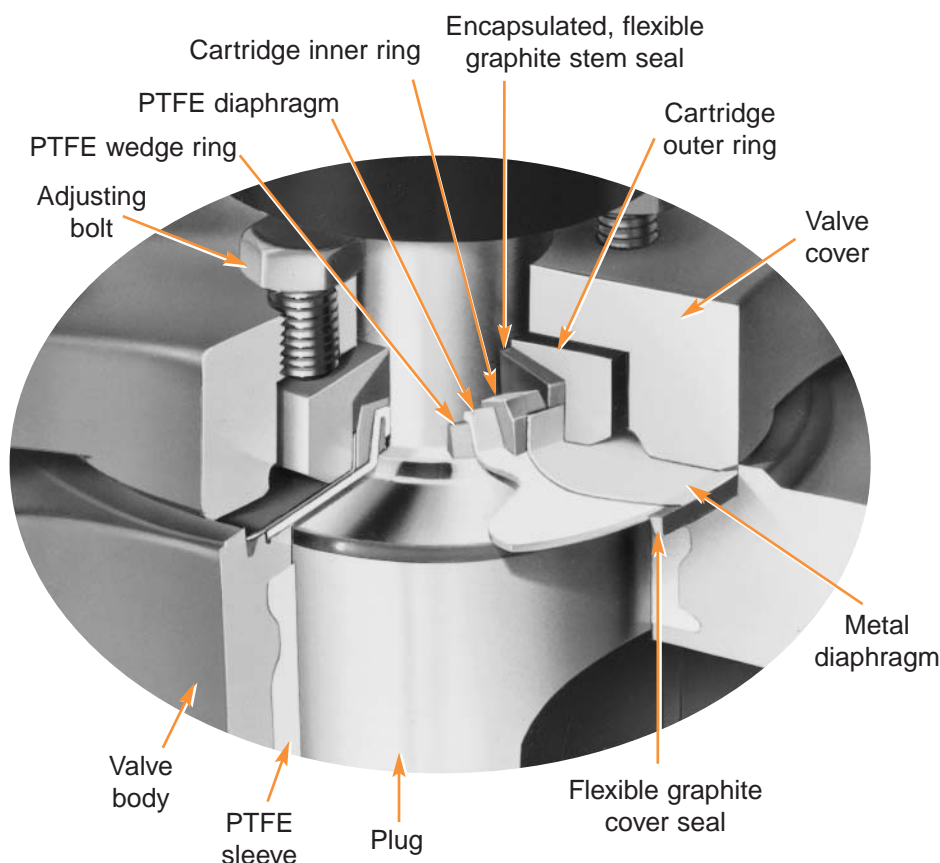

Control fugitive emissions.

This optional top seal package provides exceptional control of fugitive emissions. It meets or exceeds the most stringent current regulatory requirements.

Triple sealed for extra protection.

Under normal conditions, there are three active seals between the flow media and the atmosphere. Primary sealing is provided by the interaction of the plug, sleeve, and body.

Secondary sealing is provided by the PTFE and metal diaphragms.

Tertiary sealing is provided at the stem by the encapsulated, flexible graphite stem seal and at the body/cover joint by the graphite cover seal ring.

This simple system assures stem sealing.

This simple, compact, patented design harnesses complex dynamic forces to assure effective sealing to atmosphere.

The metallic cartridge totally encapsulates the flexible graphite tertiary dynamic stem seal.

At its outer edge, the metal diaphragm overlaps the graphite static seal ring to reinforce the tertiary seal at the body-to-cover joint.

The PTFE wedge ring concentrates the sealing force of the PTFE diaphragm radially against the valve stem for more reliable prevention of external leakage at this secondary seal.

API-607 Standards.

Like the fire tested valve, the Tufline Tertiary Top Seal Sleeved Plug valve also exceeds API-607 - Fourth Edition - Section 4.2 - Specifications For External Leakage. It is available in a broader range of sizes than the standard fire tested model.

Vented Plug.

If this valve is intended for use in a fire tested application, a vented plug is required.

Sizes: 1/2 inch - 24 inch.

Configurations: 2, 3, 4, and 5-way.
Also partially and fully jacketed.

End connections:
Screwed, flanged, socket weld, and butt weld.

Pressure ratings:
ANSI 150, 300, and 600.

Caged Plug Valves

PTFE sleeve protection.

Tufline Sleeved Plug Valves can be furnished with caged plugs. This provides soft seat protection in throttling applications and in services with high pressure drop through the valve.

Typical applications:

- Waste sludge
- Calcium carbonate slurry
- Alum
- Brine
- Green liquor
- Raw river water
- Lime mud
- Sulfuric acid with zinc powder
- Phosphoric acid slurry
- Soda ash
- ... and many others

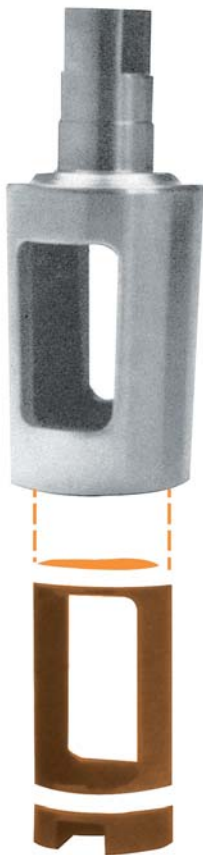

The cage is contained within the plug. It is fixed in place by pins that are welded in the bottom of the valve body. Bearings on the cage provide clearance between the plug and the cage, so the plug rotates freely.

Metal-to-metal throttling.

With caged plugs, there is metal-to-metal throttling and metal-to-soft seat shutoff. In throttling applications, the cage protects the seat from erosion by shielding the soft seat from direct flow impingement at the valve ports.

High velocity fluids.

With high velocity fluids, the cage reduces turbulence and cutting action. The cage provides a more direct, contoured flow path through the valve.

Sizes: 1" - 8".

Materials:

WCB body with CD4MCu plug and cage.

316SS body with CD4MCu plug and cage.

(Other materials upon application. Consult your Tufline Sales Engineer.)

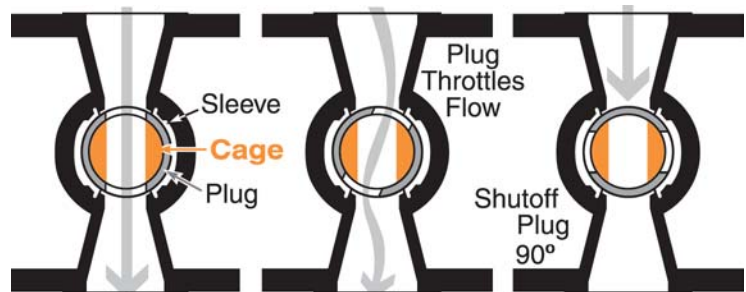

Sampling Valves

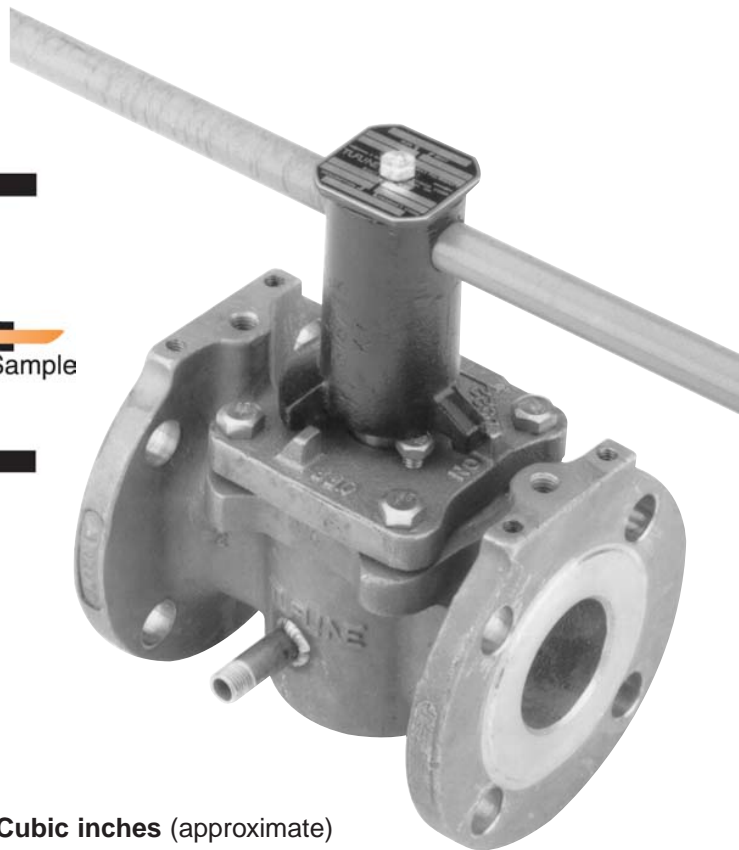
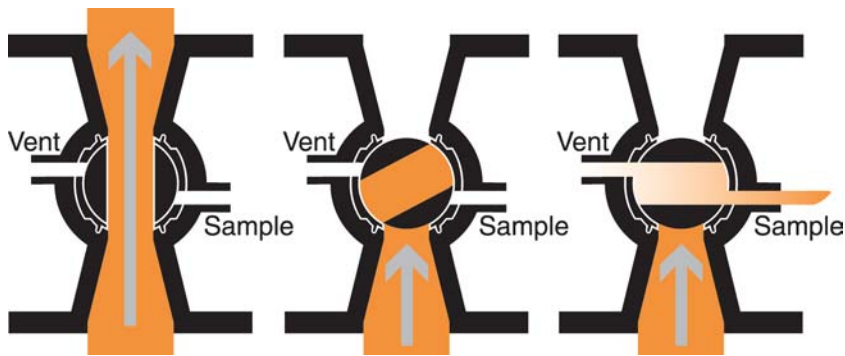

Fluid analysis, equipment evaluation, problem solving, and quality control all depend on convenient sampling.

Safe, simple sampling.

1. Valve open - normal flow.
2. As the valve is rotated and passes the intermediate position, flow is shut off. A specific amount of media is trapped within the plug. There is no trans-flow.
3. With the valve in the fully closed position, the trapped sample can be transferred into an appropriate container by operating sample and vent valving.

Plug Cavity Volume - Cubic inches (approximate)

1"	1 1/2"	2"	2 1/2"	3"	4"	6"
0.8	1.8	4.5	8.7	8.7	20	58

Infrequent use.

In many applications, sampling valves are cycled infrequently. Tufline Sampling Valves provide excellent operating reliability, even after being left open for long periods of time.

Tufline Sampling Valves are available in a full range of classes, sizes, and materials. You can also choose from several levels of fugitive emissions control.

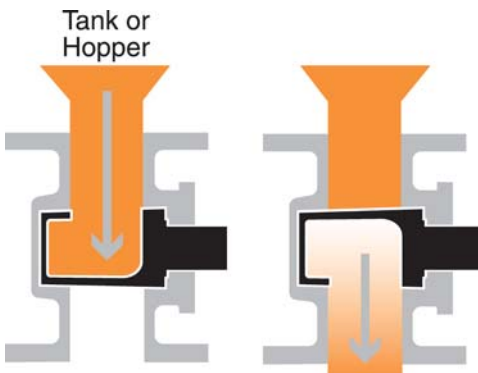

Gravity Sampling System.

Material drops from the tank or hopper into the plug cavity. The modified plug has an opening on one side only. The plug is rotated 180° and the plug contents are fed into the gravity or vacuum system pipe.

The plug rotates 180° to its original position and refills. The valve can be manually or automatically operated. A typical application is metered injection of a pelletized or liquid catalyst.

Gravity Plug Cavity Volume - Cubic inches (approximate)

1/2"	1"	1 1/2"	2"	2 1/2"	3"	4"	6"	8"
0.2	1.3	3	7	11	11	27	64	142

Additional configurations

Separate descriptive brochures and technical data are available for these valves. Ask your Sales Engineer for details.



Severe service

Tufline Severe Service Valves provide outstanding protection against external leakage, even with extreme thermal cycling.

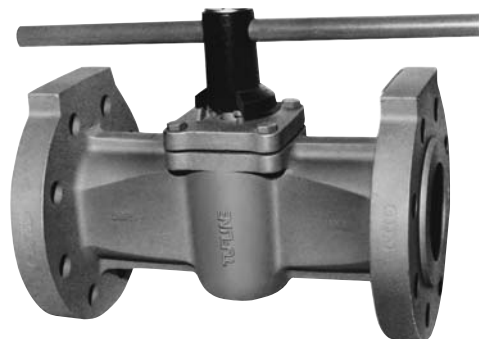

Class 600

Available in sizes 1/2" thru 24" in a wide variety of materials. Multiported also available.

Tufline XP® Sleeved Plug Valves have a patented shrink seal lip. During thermal cycling, when fugitive emissions are most likely to escape, this patented shrink-seal lip tightens the seal.

To enhance protection against leakage to atmosphere, the PTFE chevron rings provide a secondary (completely redundant) pressure-assisted stem seal.

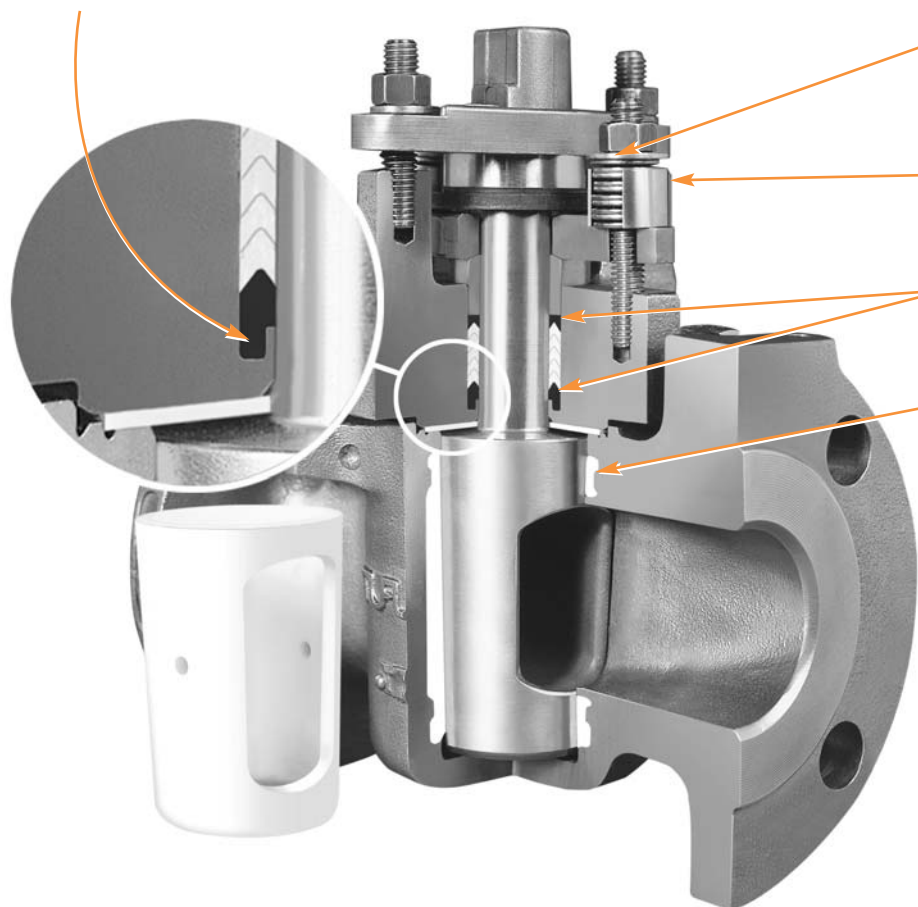

Live loaded spring washers provide a constant, uniform pressure on the packing. This is especially important during thermal cycling.

To protect the spring washers from damage and particle intrusion, they are completely enclosed.

Carbon graphite filled PTFE end rings prevent extrusion of the PTFE packing.

The primary external seal is around the top of the plug.

An optional monitoring/injection port is also available.

Vacuum

All standard Tufline valves are satisfactory for vacuum service to as low as .01 microns of absolute pressure. However, special cleaning is required to achieve this rating. Vacuum ratings have been established by independent laboratories by helium leak tests on mass spectrometers.

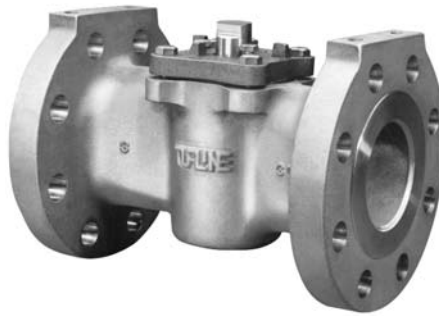

Chlorine and oxygen

Cleaning, testing, drying, sealing, and packaging are all in accordance with recommended procedures.

Product responsibility.

Xomox's concern for product performance extends to the product's period of service. We feel it is important for users to also be aware of their responsibilities. Our products are manufactured and used in numerous applications with a wide variety of service conditions. While general guidelines are often furnished, it obviously is not possible to provide complete and specific performance data for every conceivable service condition. Therefore, the end user must assume final responsibility for proper evaluation, application and performance of all products. The contents of this document are presented for information purposes only. Every effort has been made to ensure accuracy. This information is not intended to be construed as warranties or guarantees, expressed or implied, nor imply use applicability, for products or services described herein. We reserve the right to modify or improve the designs and specifications of such products at any time without notice. As the manufacturer, Xomox sells its products and services pursuant to its standard terms and conditions of sale, including its limited warranty, copies of which are available upon request. Xomox limits its liability specifically to the replacement or repair of defective items, or to a refund for same. Xomox does not accept liability for any incidental or consequential damages.



High Temperature

XENITH sleeved plug valves provide reliable shut-off in applications with temperatures up to 600° F.



Bar stock

Wetted surfaces of these valves are available in virtually any material including titanium and zirconium.



Vented plugs

Tufline valves are available with vented plugs on the upstream side. Venting the plug results in a unidirectional valve.

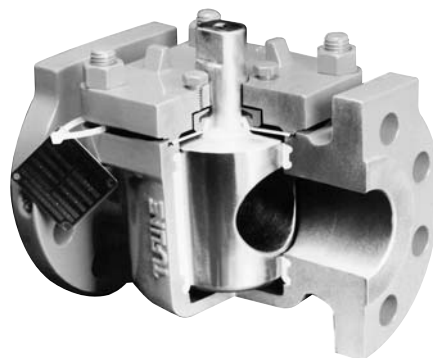

Full port

Full round bores, no cavities, and lips that remove adhering flow media all make this valve ideal for slurries, brines, muds, and sewage. Both 2-way and 3-way valves are available.

Pressure-temperature ratings

The useful range of PTFE sleeved plug valves is -20°F to +400°F
 Tuflin-475 sleeve: -20°F to +475°F
 Tuflin-600 sleeve: -20°F to +600°F
 with maximum temperature variation of 200°F.

Applications beyond these ranges can be handled effectively but may require valve adjustments at the operating temperature.

Material selections are governed by the limits imposed by ANSI B16.34, 1996 edition and B16.34a 1998 edition.

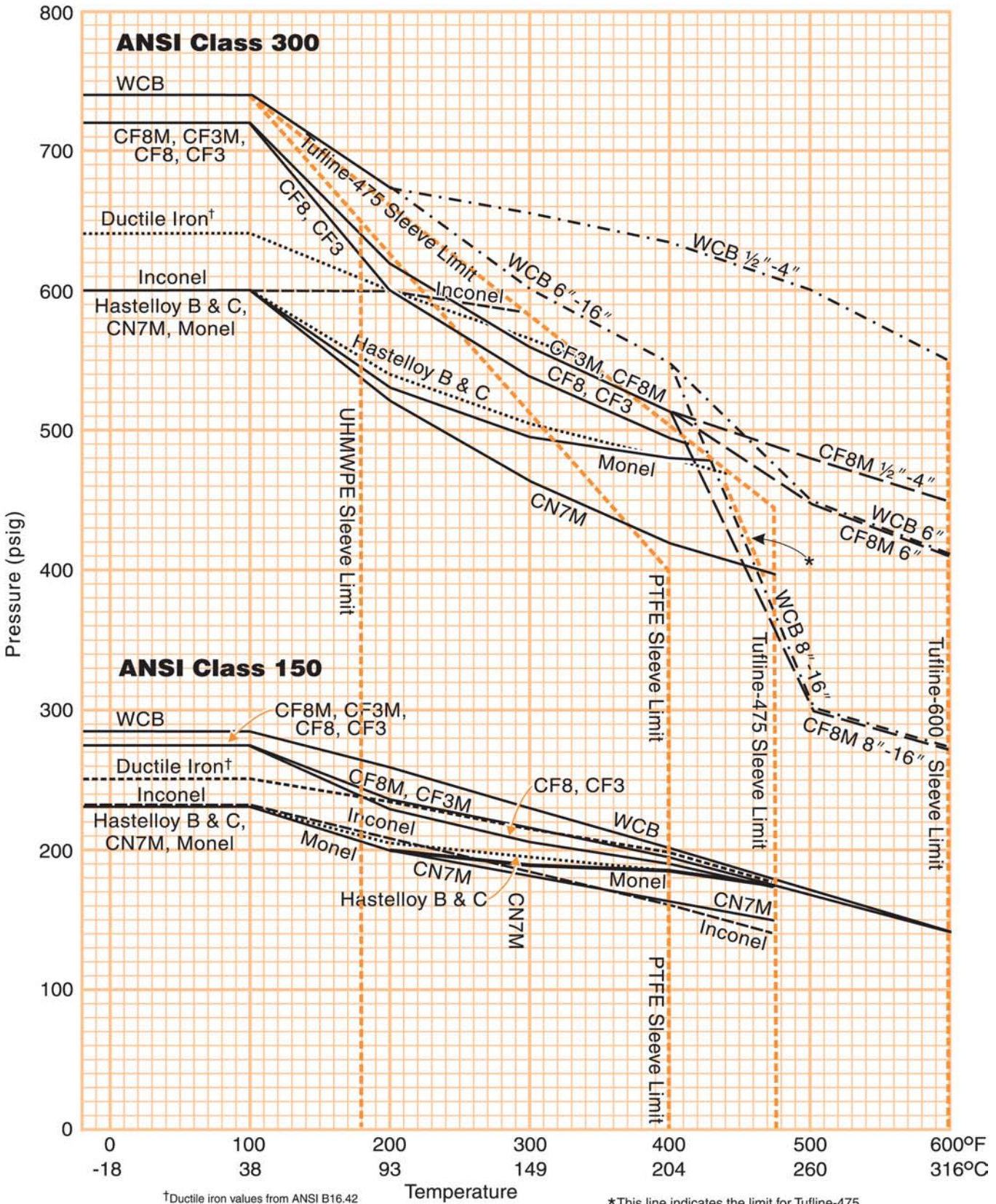

Cv factors for valve sizing

Class 150 & Class 300

Size	2-Way	3-Way A, AX, C pos.	3-Way D pos. 0° & 180°	3-Way D pos. 90°	4-Way	5-Way
1/2	9	7	4	5	4	6
3/4	9	7	4	5	6	6
1	43	20	11	17	15	27
1 1/2	89	40	21	37	30	42
2	172	70	40	47	54	69
3	294	100	54	87	74	120
4	548	175	94	159	150	200
6	1,075	350	210	255	340	390
8	1,591	475	360	450	455	575
10	2,159	650	450	750	610	785
12	3,200	965	650	1,000	900	1,160

Class 150

Size	2-Way
14	3,200
16	5,280
18	5,600
20	5,900
24	11,000

Class 300

Size	2-Way
14x12x14	3,200
14x16x14	5,280
16	5,600
18	5,900
20	11,000

Operating torques (Inch-Pounds)

Figures are for 2-Way valves with PTFE sleeves. Consult factory for torque adjustment factors for other sleeve materials.

Class 150 & 300

Size	Break Torque	Seating Torque	Running Torque
1/2	140	80	70
3/4	140	80	70
1	400	250	200
1 1/2	800	500	400
2	1,100	650	550
3	1,200	700	600
4	2,400	1,450	1,200
6	5,000	3,000	2,500
8	7,800	4,700	3,900
10	14,400	8,600	7,200
12	21,000	12,600	10,500

Class 150

Size	Break Torque	Seating Torque	Running Torque
14	21,000	12,600	10,500
16	36,000	21,000	18,000
18	36,000	21,000	18,000
20	36,000	21,000	18,000
24	100,000	60,000	50,000

Class 300

Size	Break Torque	Seating Torque	Running Torque
14x12x14	21,000	12,600	10,500
14x16x14	36,000	21,000	18,000
16	36,000	21,000	18,000
18	36,000	21,000	18,000
20	100,000	60,000	50,000

Screwed end dimensions

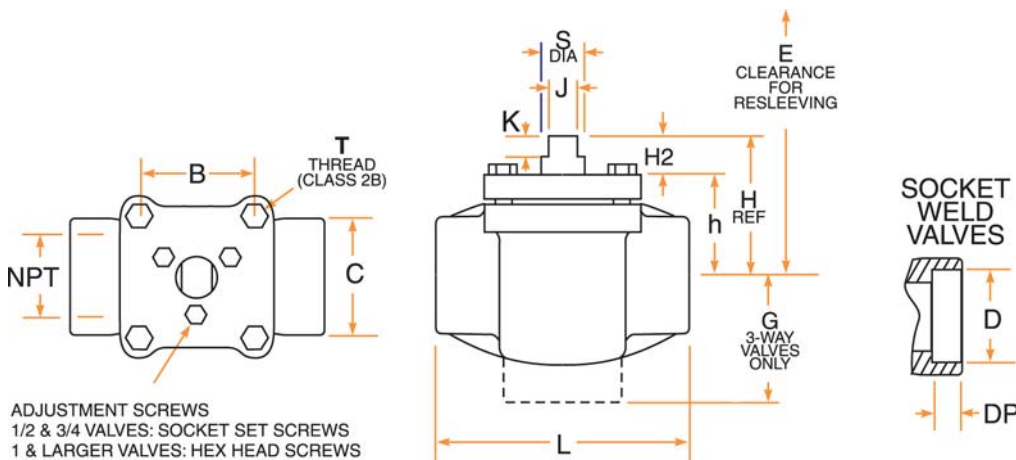

Socket Weld

Size	D	DP
1/2	.860	.38
3/4	1.070	.50
1	1.335	.50
1 1/2	1.920	.50
2	2.411	.63

Screwed End / Class 150 / 2-Way - Figure No. 066 & 3-Way Figure No. 036 Class 300 / 2-Way - Figure No. 0366 & 3-Way Figure No. 0336

Size	L	H	h	H2	B	C	S	J	K	T	E	Weight 2-Way	G 3-Way	Weight 3-Way
1/2	3.25	1.92	1.06	.86	1.43	1.68	.50	.250	.66	5/16-18	6.00	1.5	1.69	1.75
3/4	3.25	1.92	1.06	.86	1.43	1.68	.50	.250	.66	5/16-18	6.00	1.5	1.80	1.75
1	4.63	2.50	1.66	.86	1.90	2.21	.63	.438	.32	3/8-16	7.00	4	2.38	5
1 1/2	5.50	3.06	2.09	.97	2.33	2.33	.88	.563	.44	3/8-16	8.00	10	2.88	11
2	6.50	3.56	2.56	1.00	3.02	3.02	1.13	.750	.53	7/16-14	9.13	14	3.38	16

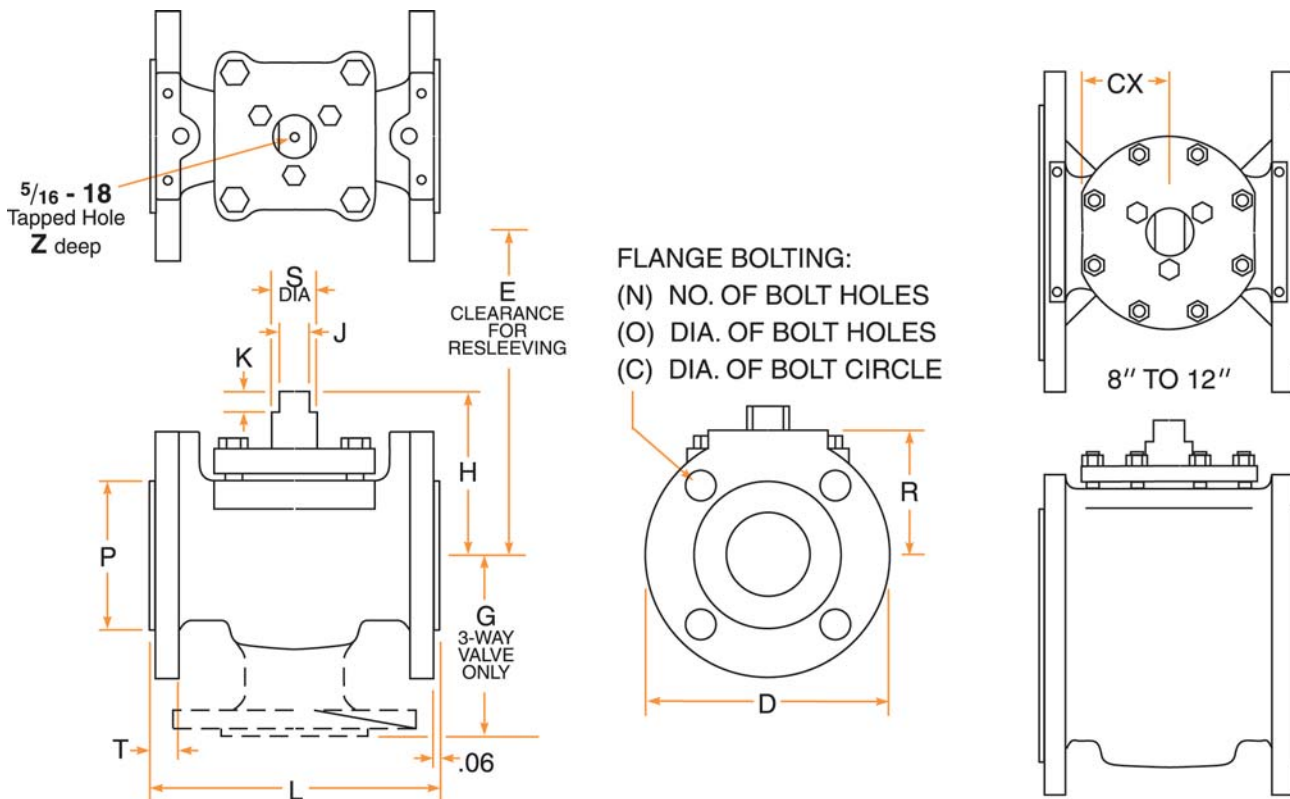

Dimensions

Flanged End / Class 150 / 2-Way - Figure No. 067 & 3-Way Figure No. 037

Size	L	H	D	T	P	R	N	O	C	S	J	K	E	Z	CX	Weight 2-Way	G 3-Way	Weight 3-Way
1/2	4.25	1.92	3.50	.38	1.38	1.75	4	.63	2.38	.50	.250	.66	6.00	-	1.09	2.8	2.75	3.8
3/4	4.63	1.92	3.88	.41	1.69	1.94	4	.63	2.75	.50	.250	.66	6.00	-	1.09	3.3	2.88	4.5
1	5.00	2.50	4.25	.44	2.00	2.13	4	.63	3.13	.63	.438	.32	7.00	.53	1.38	6.5	3.50	9
1 1/2	6.50	3.06	5.00	.56	2.88	2.50	4	.63	3.88	.88	.563	.44	8.00	.59	1.56	13	4.13	17
2	7.00	3.56	6.00	.63	3.63	3.00	4	.75	4.75	1.13	.750	.53	9.13	.78	2.00	20	4.50	26
2 1/2†	8.00	4.13	7.50	.75	4.13	3.75	4	.75	5.50	1.13	.750	.53	10.13	.78	2.00	31	5.13	42
3	8.00	4.13	7.50	.75	5.00	3.75	4	.75	6.00	1.13	.750	.53	10.13	.78	2.00	31	5.13	42
4	9.00	5.22	9.00	.94	6.19	4.63	8	.75	7.50	1.25	.875	.78	22.00	.90	2.50	54	6.00	69
6	10.50	7.35	11.00	1.00	8.50	5.50	8	.88	9.50	2.00	1.398	1.00	25.00	-	3.06	95	7.50	119
8	11.50	9.32	13.50	1.13	10.63	6.75	8	.88*	11.75	2.00	1.398	1.00	28.00	-	4.12	175	9.00	214
10	13.00	10.81	16.00	1.19	12.75	8.00	12	1.00*	14.25	2.50	1.673	1.00	29.00	-	4.50	260	11.00	331
12	14.00	11.81	19.00	1.25	15.00	9.50	12	1.00*	17.00	3.00	1.968	1.00	35.00	-	5.31	355	-	-
14	15.00	11.75	21.00	1.38	16.25	10.50	12	1.13*	18.75	2.97	1.968	.995	N/A	-	5.31	430	-	-
16	30.00	14.96	23.50	2.12	18.50	11.50	16	1.13	21.25	3.94	2.00	1.575	N/A	-	N/A	925	-	-
18	33.00	14.96	25.50	2.25	21.00	12.75	16	1.25	22.75	3.94	2.00	1.575	N/A	-	N/A	1,005	-	-
20	36.00	14.96	27.50	2.38	23.00	14.00	20	1.25	25.00	3.937	2.00	1.575	N/A	-	N/A	1,200	-	-
24	39.00	20.48	32.00	2.50	27.25	16.13	20	1.38*	29.50	6.00	4.00	2.000	N/A	-	N/A	2,500	-	-

* On 8" valves, the two top holes in the flange are tapped for 3/4-10UNC-2B threads.

On 10" and 12" valves, the two top holes in the flange are tapped for 7/8-9UNC-2B threads.

On 14" valves, the two top holes in the flange are tapped for 1-8UNC-2B threads.

On 24" valves, the top six holes in the flange are tapped for 1 1/4-8UNC-2B threads.

† 2 1/2" valves are machined from 3" castings, but the flanges are machined to 2 1/2" dimensions.

Dimensions are in inches. Weights are in pounds.

Flanged End / Class 300 / 2-Way - Figure No. 0367 & 3-Way Figure No. 0337

Size	L	H	D	T	P	R	N	O	C	S	J	K	E	Z	CX	Weight 2-Way	G 3-Way	Weight 3-Way
1/2	5.50	1.92	3.75	.56	1.38	1.88	4	.63	2.63	.50	.250	.66	6.00	-	1.09	6	2.88	8
3/4	6.00	1.92	4.63	.63	1.69	2.31	4	.75	3.25	.50	.250	.66	6.00	-	1.09	9	3.00	12
1	6.50	2.50	4.88	.69	2.00	2.44	4	.75	3.50	.63	.438	.32	7.00	.53	1.38	11	3.75	15
1 1/2	7.50	3.06	6.13	.81	2.88	3.06	4	.88	4.50	.88	.563	.44	8.00	.59	1.56	21	4.38	29
2	8.50	3.56	6.50	.88	3.63	3.25	8	.75	5.00	1.13	.750	.53	9.13	.78	2.00	28	4.75	37
2 1/2†	11.13	4.13	8.25	1.13	4.13	4.13	8	.88	5.88	1.13	.750	.53	10.13	.78	2.00	38	5.56	53
3	11.13	4.13	8.25	1.13	5.00	4.13	8	.88	6.63	1.13	.750	.53	10.13	.78	2.00	38	5.56	53
4	12.00	5.22	10.00	1.25	6.19	5.13	8	.88	7.88	1.25	.875	.78	22.00	.90	2.50	80	6.75	105
6	15.88	7.35	12.50	1.44	8.50	6.25	12	.88	10.63	2.00	1.398	1.00	25.00	-	3.06	165	8.50	207
8	16.50	9.32	15.00	1.63	10.63	7.50	12	1.00	13.00	2.00	1.398	1.00	28.00	-	4.12	267	10.00	334
10	18.00	10.81	17.50	1.88	12.75	8.75	16	1.13	15.25	2.50	1.673	1.00	29.00	-	4.50	395	12.00	470
12	19.75	11.81	20.50	2.00	15.00	10.25	16	1.25	17.75	3.00	1.968	1.00	35.00	-	5.31	540	-	-
14	30.00	14.96	23.00	2.12	16.25	11.50	20	1.25*	20.25	3.937	2.00	1.575	N/A	-	N/A	925	-	-
16	33.00	14.96	25.50	2.25	18.50	12.75	20	1.38	22.50	3.937	2.00	1.575	N/A	-	N/A	1,005	-	-
18	36.00	14.96	28.00	2.38	21.00	14.00	24	1.38	24.75	3.937	2.00	1.575	N/A	-	N/A	1,200	-	-
20	39.00	20.48	32.00	2.50	23.00	16.13	16	1.38	27.00	6.00	4.00	2.00	N/A	-	N/A	2,500	-	-

* On 14" valves, the two top holes in the flanges are tapped for 1-8UNC-2B threads.

† 2 1/2" valves are machined from 3" castings, but the flanges are machined to 2 1/2" dimensions.

Dimensions are in inches. Weights are in pounds.

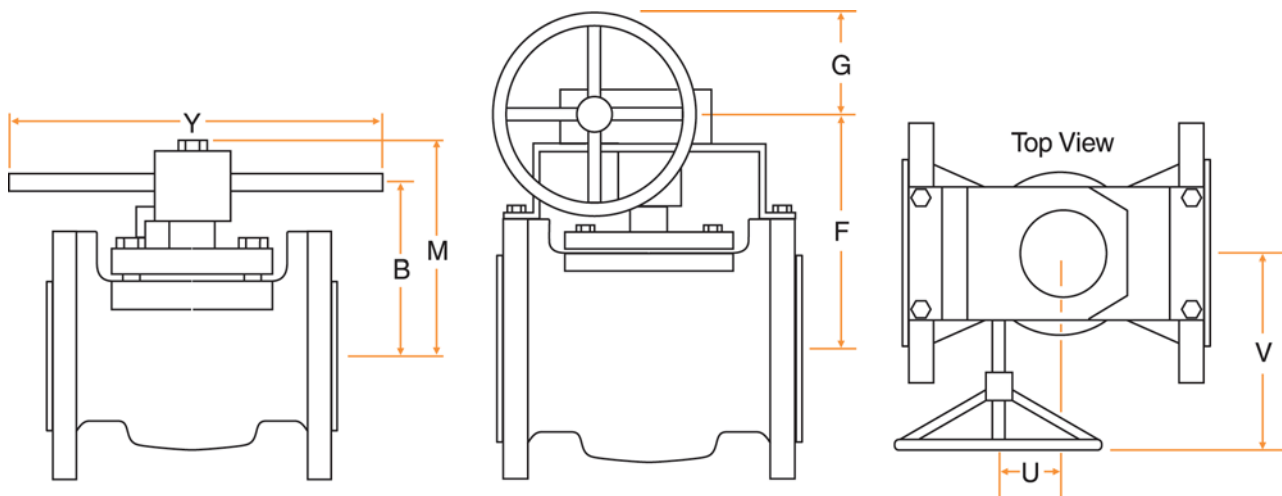

Wrench & Enclosed Gear Operator Dimensions

These operator dimensions apply to all flange types and all multiport valves.

Size	M	B	Y
1/2	-	4.00	6.38
3/4	-	4.00	6.38
1	3.81	2.88	8.75
1 1/2	4.56	3.63	12.50
2	5.13	4.00	18.00
2 1/2	5.69	4.63	24.00
3	5.69	4.63	24.00
4	7.06	5.75	30.00

Size	F	G	U	V
4	8.75	6.00	2.06	8.00
6	11.50	9.00	2.62	10.38
8	13.50	9.00	2.62	10.38
10	15.25	12.00	3.53	12.31
12	16.25	15.00	4.88	15.88
14	21.66	15.00	5.38	16.90
16	21.66	12.00	5.12	17.66
18	21.66	12.00	5.12	17.66
20	32.92	15.75	16.97	24.00
24	32.92	15.75	16.97	24.00

Manual Operators

A wide variety of handle and gear operators are available.

You can choose from chain wrenches, T-wrenches, chain wheels, and tandem adapters.

Talk with your Tufline Sales Engineer about your specific requirements, sizing, and how to order.

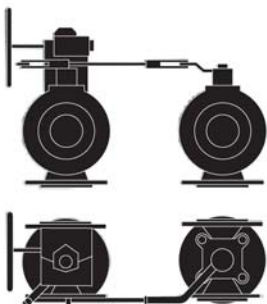
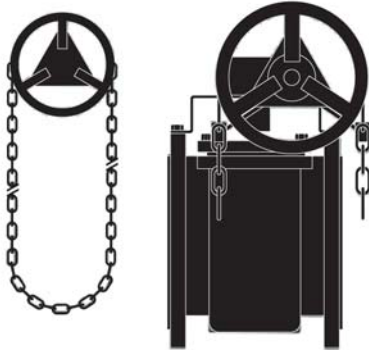
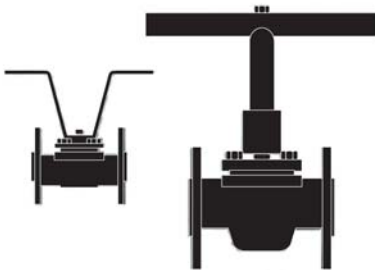
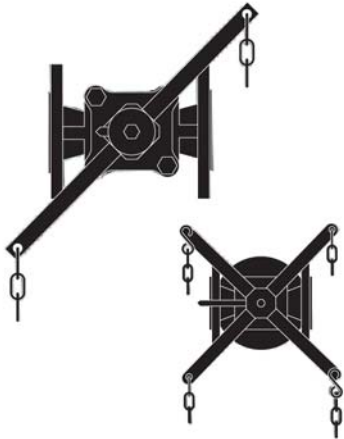

Automation Accessories



Actuators

- * A balanced pinion which does not require an external retaining clip to prevent the pinion from blowing out.
- * Individual single point adjustment for both the CW and CCW directions.
- * 98 degrees of total travel on the most popular sizes.
- * Vertically aligned air passages allow increased air flow minimizing cycle time.



Limit Switches

A wide variety of switching options and other automation accessories are available.



Pinion Actuators

Matryx Rack & Pinion Actuators have a unique suspension system that guides each piston smoothly through its complete stroke, insuring consistent torque output.

Locking Devices

Specify whether the valve is to be locked open, closed, or both. (The lock is not supplied.)

Vane Actuators

Matryx Vane Actuators provide reliable and efficient remote control of any type of rotary operation. They are used for ball, plug, and butterfly valves as well as other mechanisms such as dampers, switches, and safety devices. They are available up to 30,000 in-lbs of torque.

Actuator mounting hole configurations

Full dimensions for valve and actuator assemblies are available.

Class 150

Size	4 hole pattern				2 hole pattern		
	A	AY	W	X	A	W	X
1/2	-	-	-	-	3.62	5/16-18	.47
3/4	-	-	-	-	3.75	5/16-18	.47
1	4.19	1.75	5/16-18	.38	-	-	-
1 1/2	5.75	1.75	5/16-18	.47	-	-	-
2	6.31	2.25	5/16-18	.47	-	-	-
2 1/2	7.13	3.50	3/8-16	.56	-	-	-
3	7.13	3.50	3/8-16	.56	-	-	-
4	8.00	4.00	7/16-14	.63	-	-	-
6	9.44	4.00	7/16-14	.63	-	-	-
8	10.19	6.00	1/2-13	.63	-	-	-
10	11.56	6.00	1/2-13	.63	-	-	-
12	12.53	6.00	1/2-13	.63	-	-	-
14	13.750	6.00	1/2-13	.63	-	-	-
16	27.812	8.00	5/8-11	1.00	-	-	-
18	30.688	8.00	5/8-11	1.00	-	-	-
20	33.56	8.00	5/8-11	1.00	-	-	-
24	36.25	11.50	1.00-8	1.50	-	-	-

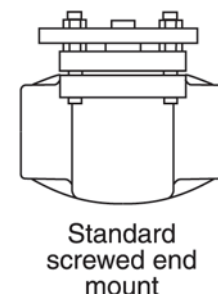
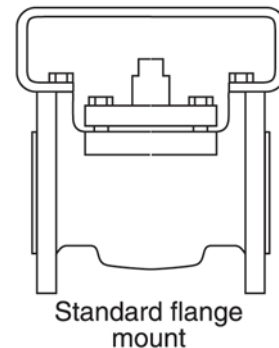
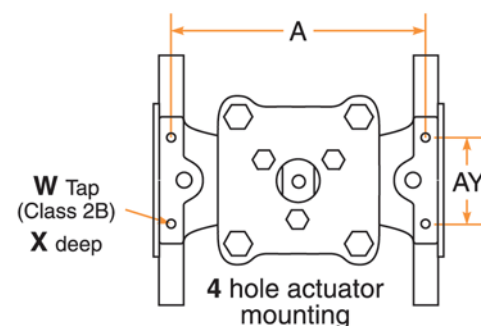
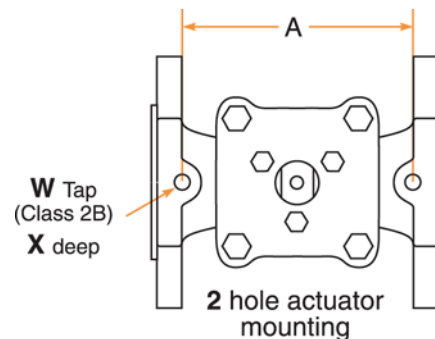

Class 300

Size	4 hole pattern				2 hole pattern		
	A	AY	W	X	A	W	X
1/2	-	-	-	-	4.38	5/16-18	.47
3/4	-	-	-	-	4.38	5/16-18	.47
1	5.75	1.75	5/16-18	.38	-	-	-
1 1/2	6.63	1.75	5/16-18	.47	-	-	-
2	7.56	2.25	5/16-18	.47	-	-	-
2 1/2	9.94	3.50	3/8-16	.56	-	-	-
3	9.94	3.50	3/8-16	.56	-	-	-
4	10.69	4.00	7/16-14	.63	-	-	-
6	14.00	4.00	7/16-14	.63	-	-	-
8	14.63	6.00	1/2-13	.63	-	-	-
10	15.69	6.00	1/2-13	.63	-	-	-
12	17.38	6.00	1/2-13	.63	-	-	-
14	27.812	8.00	5/8-11	1.00	-	-	-
16	30.688	8.00	5/8-11	1.00	-	-	-
18	33.563	8.00	5/8-11	1.00	-	-	-
20	36.25	11.50	1.00-8	1.50	-	-	-

Dimensions are in inches.

Quick Reference Selection Table

The table below provides a brief overview of the most commonly specified valves. When ordering, be sure to specify all options including body, plug, and sleeve materials.

No. of Ports	Type*	ANSI Class	Size Range	Operator	Figure Number	Notes
2	Screwed End	150	1/2-2	Wrench	066	2-way Tufline Sleeved Plug Valves provide tight shutoff from high vacuum through rated pressure at temperatures from -20°F to 600°F
		300			0366	
	Flanged End	150	1/2-4	Enclosed Gear	067	
			4-24		067EG	
		300	1/2-4	Wrench	0367	
			4-24	Enclosed Gear	0367EG	
	Partial Jacket	150	1-4	Wrench	067PJ	Standard jacketed valves are available in carbon steel or 316 stainless steel. All jackets are rated at 235 psi at 400°F. Full jacketed valves have over-sized flanges.
			4-12	Enclosed Gear	067PJ-EG	
		300	1-4	Wrench	0367PJ	
			4-12	Enclosed Gear	0367PJ-EG	
	Full Jacket	150	2x1x2-6x4x6	Wrench	067FJ	
			6x4x6-12x10x12	Enclosed Gear	067FJ-EG	
300		2x1x2-6x4x6	Wrench	0367FJ		
		6x4x6-12x10x12	Enclosed Gear	0367FJ-EG		
3	Screwed End	150	1/2-2	Wrench	036	When ordering 3-way valves, be sure to include the port configuration. Refer to page 5.
		300	1/2-2		0336	
	Flanged End	150	1/2-4	Enclosed Gear	037	
			4-12		037EG	
		300	1/2-4	Wrench	0337	
			4-12	Enclosed Gear	0337EG	
	Partial Jacket	150	1-4	Wrench	037PJ	
			4-8	Enclosed Gear	037PJ-EG	
		300	1-4	Wrench	0337PJ	
			4-8	Enclosed Gear	0337PJ-EG	
4	Screwed End	150	1/2-2	Wrench	046	Bodies are available in carbon steel or 316 stainless steel. Standard pressure/temperature ratings apply, with the exception that pressure drop should not exceed 170 psi at 100°F when switching.
	Flanged End		1/2-4		047	
	Flanged End		6-12	Enclosed Gear	047-EG	
5	Screwed End	150	1/2-2	Wrench	056	
	Flanged End		1-4		057	

* Socket weld and butt weld end valve information is available in a separate catalog.

Materials

The following are ASTM designations for materials listed elsewhere in this catalog.

Carbon steel	ASTM A216 WCB
302 stainless steel	ASTM A240 Type 302
304 stainless steel	ASTM A240 Type 304
304 stainless steel	ASTM A351 CF8
304L stainless steel	ASTM A351 CF3
316 stainless steel	ASTM A351 CF8M
316L stainless steel	ASTM A351 CF3M
Alloy 20	ASTM A351 CN7M
Bronze	ASTM B61
CD4MCu	ASTM A351 CD4MCu
Ductile Iron	ASTM A395
Hastelloy B	ASTM A494 N7M
Hastelloy C	ASTM A494 CW6M
Inconel	ASTM A494 CY40
Nickel	ASTM A494 CZ-100
Monel	ASTM A494 M30-C
Ni-Al Bronze	ASTM B148 Gr.958
Titanium	ASTM B367 Gr. C-3
Zirconium	ASTM B752 Gr. 702

Other ferrous and non-ferrous materials are available upon application.

How to specify

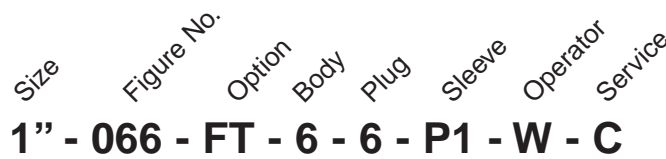

Size & Figure No.

See Quick Reference Selection Table on the previous page

Options

Fire TestedFT
Tertiary Top SealTS
Cage ControlCCV
Extended PackingXP
Partial JacketPJ
Full JacketFJ
Port Arrangements for 3-Way valves (See page 6)	.A, AX, C, or D

Valve specifications may include multiple options.

Body

Alloy 200
Ductile Iron1
Carbon Steel2
Monel3
Nickel5
316SS6
Hastelloy B8
Hastelloy C9
CD4MCu27
Inconel40
Other (Specify)X

Service

ChlorineC
OxygenO
VacuumV
General ServiceBlank
Other**X

Operator

Less OperatorN
WrenchW
Wrench with locking deviceWY
GearG
Gear with locking deviceGZ
Actuator*A

Sleeve

PTFEP1
15% RPTFEP2
25% RPTFEP3
PFAP6
Xomox-7P7
UHMWPEP8
Tufline-475P16
Tufline-600P20
Other (Specify)PX

Plug

Alloy 200
Ductile Iron1
Carbon Steel2
Monel3
304SS4
Nickel5
316SS6
Hastelloy B8
Hastelloy C9
CD4MCu27
Inconel40
Other (Specify)X

* Specify actuator type and available air supply.