

CHECK VALVES



Double Door Check Valves:

Product Information	1- 4
Standard Materials of Construction	5
Material of Construction and Ordering Information	5
Installation Dimensions for Wafer Body ANSI Check Valves	6
Installation Dimensions for Lug Body ANSI Check Valves	7
and Flanged Body ANSI Check Valves	7
Head Loss Chart	8
ANSI Stud Bolting Dimensions	9
Installation Data	9
Pressure Loss Through Valves	10
Seat Options / Simple Installation	11
Quality Information	12
Cast Iron Wafer Double Door – Dual Disc Check Valve	13

Swing Check Valves:

Ductile Iron Elastic Swing Flanged Check Valve	14
Cast Iron Horizontal Swing Flanged Check Valve	15
Cast Iron Wafer Swing Disc Check Valve	16
Stainless Steel Wafer Swing Disc Check Valve	17

Silent Check Valves:

Cast Iron Flat Face Wafer Silent Check Valve	18
Cast Steel & Cast 316SS Wafer Silent Check Valve	19
Cast Iron Silent or Globe Flanged Silent Check Valve	20
Cast Steel & Cast 316SS Silent or Globe Flanged Silent Check Valve	21
Pressure Drop Charts	22

Foot Valves:

Ductile Iron Elastic Swing Flanged Foot Valve	23
Cast Steel & Cast 316SS Elastic Hinge Flanged Foot Valve	24
Cast Steel & Cast 316SS Elastic Hinge Threaded Foot Valve	25
Cast Iron, Cast Steel & Cast 316SS Silent Seat Flanged Foot Valve	26
Foot Valve Assembly	27

Warranty	28
----------------	----

Sure Flow Equipment Inc., for many years, has provided industry with **CUSTOM ENGINEERED FABRICATED STRAINERS** to many design codes. All products are designed and manufactured to **ASME SECTION VIII, DIV 1, CURRENT EDITION. U and UM CODE STAMP** available on certain products as specified in this brochure.

Sure Flow's initial focus was to supply the marketplace with an extensive line of Y-Type Strainers, Simplex Strainers, Duplex and Fabricated Strainers. The product line provides a solution to every filtration problem in every industry and if we haven't already solved your problem, our Engineers will develop the best answer.

In addition to Pipeline Strainers, Sure Flow offers Wafer Double Door Check Valves, Silent Check Valves, Butterfly Valves 2" to 48", Knife Gate Valves and Expansion Joints and Automatic Strainers.

Sure Flow products are available in Cast Iron, Steel, Stainless, Bronze, and any exotic Alloy, in sizes from 1/4" to 60", 125 lb. to 2500 lb. Class, in NPT, Flanged, Butt Weld and Socket Weld.

Many design codes are available.

The Universe of Industrial Valves



Check Valves

The wafer check valve is a precision engineered, fully developed product at the forefront of pipe system technology. can be installed with confidence into offshore or onshore pipeline systems on product or service lines, wherever non-return protection is required.

Manufactured to meet API specifications, meets all the key criteria and in the vitally important area of comparative weights is actually lighter than other wafer check valves.

offers other operational benefits. **It is light, tight, strong, compact and cost effective.**

is a precision engineered dual plate wafer check valve. It has been designed specifically for its environment and its duty. Every component has been carefully chosen only after matching its performance requirements with value analysis criteria.

The Valve meets API 594 wafer check valve standard (except face to face dimensions of ANSI 125 cast iron valves from 2-1/2" to 12" in which case they meet the Industry Standard).

- ANSI B16.5 flange dimension
- ANSI B16.47 above 24", flange dimension
- API 594 – materials, design & face to face
- API 605 (B16.47), flange dimension
- API 6A – flange dimension & face to face
- API 6D – materials
- API 598 – testing
- ANSI B16.34 – materials, wall thickness

Double Door or Dual Disc Available Wafer • Flanged • Hub • Lug



Range of Valves

- | | | | |
|----------------------|-------------------------------|-------------------|------------------------------|
| Sizes: | • 2" to 72" | Materials: | • Cast or Forged |
| Pressures: | • ANSI Class 125 & 250 | | • Cast Iron, Cast Steel |
| | • ANSI Class 150 to 2,500 | | • Stainless Steel & Bronze |
| | • API 2,000# to 10,000# | Types: | • Flanged |
| Temperatures: | • Minus 400°F. to 1,200°F. | | • Flangeless (Wafer Style) |
| Seating: | • Resilient or Metal to Metal | | • Lug (Drilled or Threaded) |
| | | | • Butt Weld |
| | | | • Hub End (for Clamp Joints) |

Check Valves

Lighter

Wafer check valves are recognized as being substantially lighter in weight than conventional swing check valves of the same size and pressure class.

For example:

6 "class 150 swing check weighs 175 lbs.

6 "150 weighs only 30 lbs.

This weight advantage means that the whole pipework system is lighter, consequently the pipework support structure can also be lighter and installation costs reduced.



Stronger

Lighter weight does not mean, however, that strength has been sacrificed. In fact a is actually stronger than the equivalent length of pipe. Ribs around the side wall support the flange faces.

The Valve provides the following important features:

- ◆ Twin plate, flat seat design for efficient sealing.
- ◆ Long leg spring(s) allows the plates to open and close without seat scrubbing.
- ◆ Valves 14 "and larger are fitted with patented independent spring(s) as a standard feature.
- ◆ Lower head loss than swing checks above 6 ".
- ◆ Valves with soft seats have bubble tight closure to API 6D.
- ◆ Valves with metal/hardfaced seats have low leakage in accordance with API 598.
- ◆ Simplicity of installation is a key feature.
- ◆ A wide range of seat options is available.

The strong central rib gives rigidity to the body, protects the mechanism from damage by foreign objects in the flow and also provides a broad seating area for the plate heels.

The pins which support the plates and anchor the spring are substantial in order to withstand the pressures imposed on them by the flow.



If the rib profile and size are reduced or the pins are slimmed down, the valve might not provide the safety margin in operation which is one of the main reasons for having a wafer check valve in the first place.



Compact

meets the internationally accepted API 594 standard for steel valves. A 6 "class 150 valve has a face to face measurement of just 3 "compared with a swing check valve's 14 " face to face dimension. A fits completely inside the flange bolt PCD and therefore external installation is straightforward.

Non-Slam

is a non-slam check valve because it operates on flow cessation, not flow reversal. The normal position of the plates is closed, held against the seat by the unique spring design. As flow begins, the heels of the two plates are lifted off the seat face on the central rib.

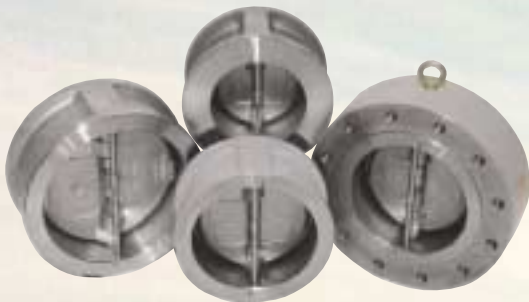

This cracking pressure is less than 2 psi across most of the range. As flow increases, the plates then pivot against the spring pressure. Since the heels have already lifted off the rib seat there is no scrub or wear, either on the rib, body or plate seating surfaces. A pressure of only 4 psi is required to keep the plates fully open.

When flow stops and that pressure is removed the spring closes the plates. Flow reversal is then stopped by the closed valve and in fact any back pressure only serves to make the valve seal more tightly.

Tight

The long leg spring design - with a single anchor point - is a unique feature of the design. Coupled with floating plates for minimum seat wear and the right choice of seat to suit the service requirements, this gives the best combination to meet API 598 requirements.



The long spring leg ensures closing tension is applied to the right part of the plate whilst allowing the plate heels to float on opening. For valves 14 "and larger, the spring is anchored to the stop pin to ensure that both plates open and close independently. If the spring is not anchored, then the opening of one plate transfers pressure through the spring to make it more difficult for the other plate to open.

Check Valves

Sure Flow Retainerless body design

In standard or competitive designs, some manufacturers drill four holes through the body of the check valve to facilitate the installation of a hinge pin and stop pin. The valves are then sealed by four pipe plugs. These holes are potential leak paths from the body of the valve.

Sure Flow Equipment Inc. utilizes an internal stop pin and hinge pin which are machined into the cavity of the body wall. This design eliminates a potential shell or body leak path.

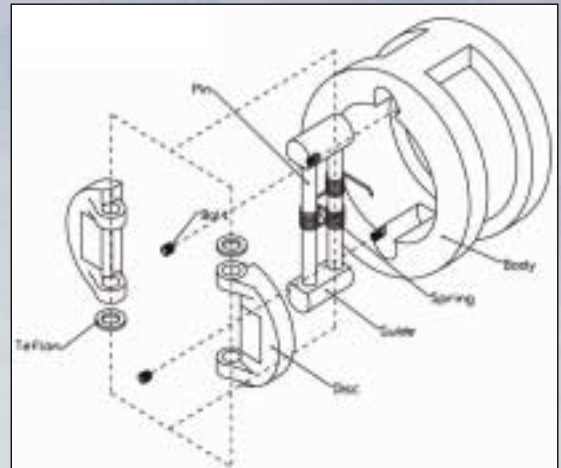

Lapped body / disc seal

All valves meet or exceed API 598. When it comes to the Sure Flow metal to metal valve, an additional special machining cure is performed to provide a maximum flatness and a fine, lapped finish. The Sure Flow disc provides an almost zero leakage on metal seated valves with no additional cost.



Shock bumpers

Sure Flow Equipment Inc. has cast "Shock Bumpers" into the reverse side of each of the discs (flappers). Both sides of the disc meet or touch in the fully open position, thus preventing them from contact with the internal pins. This reduces the force on the hinges to a minimum.

In some competitive designs the disc (flapper) strikes the stop pin in the fully open position, creating a lever force which could cause the hinge pin to break. The Shock Bumpers eliminate this potential problem.



Seat life

Increased seat life is obtained by eliminating the problem of dragging on the seat when opening. The soft seated valve has a seat molded to the body by use of a heating temperature suitable to the materials.

Standard Materials of Construction

ANSI 150 through 2500 Series Body & Plate Castings

ASTM A216 Grade WCB
Carbon Steel (0.22% Carbon Max.)

ASTM A217 Grade CA15
Stainless Steel (410)

ASTM A351 Grade CF8M
Stainless Steel (316)

BS 1400 Grade AB2 Aluminum Bronze
(ANSI 150 & 300 Series)

Other materials available on request.

Valve Parts Explosion

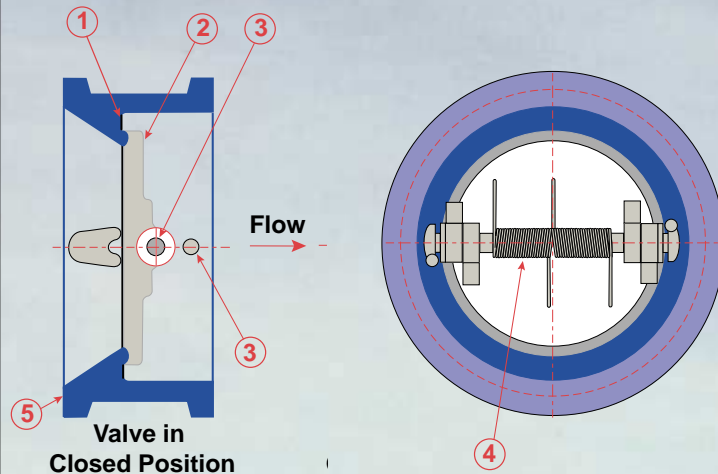

No	Description
1	Seat/Seal
2	Disc
3	Shaft
4	Torsion Spring
5	Cast Body

Springs

316 SS
Inconel 600
Inconel X 750

Max. Operating Temperature

120°C (248°F)
315°C (600°F)
537°C (1000°F)

Spring Selection

For temperatures up to 315°C (600°F), Inconel springs will be furnished as standard on all valves that are ordered with metal and Viton seats. For service conditions above 315°C (600°F), Inconel X springs should be specified.

For Seal Selection Refer to Ordering Information

Identification Code/Figure Number

EXAMPLE

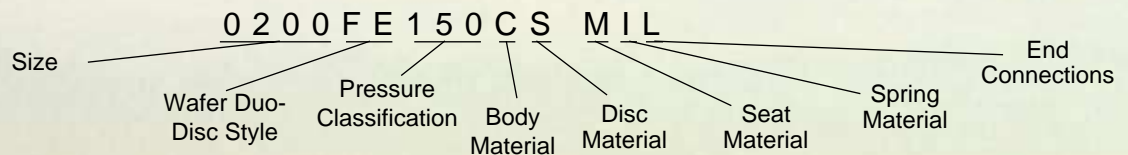

Pressure Classification						
Code	150	300	600	900	1500	2500
ANSI	150	300	600	900	1500	2500

Body and Flapper Materials		
Code	Material	Specification
C	Carbon Steel	ASTM A216 Grade WCB
S	Stainless Steel	ASTM A351 Grade CF8M

Seat Material	
Code	Material
M	Metal
V	Viton

Spring Material		
Code	Material	Max. Temp. F.
I	Inconel	600°F

End Connectors	
Code	Connection
R	Serrated Gasket Finish
L	Lug 2" - 10"
F	Flanged 12" - 24"

Check Valves

Installation Dimensions for Wafer Body ANSI Check Valves

Class 150 Model FE 150 Wafer

Size Inches	Face to Face	Outside Dia.	Min. Flange Bore	Shipping Weight (lbs)
2	2 3/8	4 1/8	2 3/8	6
2 1/2	2 3/8	4 7/8	2 5/16	8
3	2 7/8	5 3/8	3 3/4	10
4	2 7/8	6 7/8	4 1/2	17
5	3 1/4	7 11/16	5 11/16	23
6	3 7/8	8 3/4	6 5/8	33
8	5	11 11/16	8 5/8	58
10	5 3/4	13 3/8	10 3/4	109
12	7 1/8	16 1/8	12 5/8	180
14	7 1/4	17 3/4	13 11/16	206
16	7 1/2	20 1/4	16 11/16	263
18	8	21 5/8	18	334
20	8 5/8	23 7/8	20 1/4	430
24	8 3/4	28 1/4	23 3/4	582
26	11 1/4	30 1/2	24 3/4	1,151
28	12 5/8	32 3/4	27 5/8	1,293
30	12	34 13/16	30 1/8	1,356
32	14	37	30 11/16	1,746
36	14 1/2	41 1/4	34	2,125
40	17	45 3/4	38 13/16	3,011
42	17	48	41 13/16	3,795
48	20 5/8	54 1/2	47	5,566
54	21 1/4	60 7/8	50 1/2	6,831

Class 300 Model FE 300 Wafer

Size Inches	Face to Face	Outside Dia.	Min. Flange Bore	Shipping Weight (lbs)
2	2 3/8	4 3/8	2 3/8	6
2 1/2	2 3/8	5 1/8	2 5/16	8
3	2 7/8	5 7/8	3 3/4	13
4	2 7/8	7 1/8	4 1/2	20
5	3 1/4	8 1/2	5 3/4	23
6	3 7/8	9 7/8	6 5/8	38
8	5	12 1/8	8 5/8	71
10	5 3/4	14 1/4	10 3/4	124
12	7 1/8	16 5/8	12 5/8	195
14	8 3/4	19 1/8	13 3/4	339
16	9 1/8	21 1/4	16 11/16	428
18	10 3/8	23 1/2	18	595
20	11 1/2	25 1/2	20 1/4	774
24	12 1/2	30 1/2	23 3/4	1,207
26	14	32 7/8	24 3/4	1,569
28	15	35 3/8	27 5/8	1,946
30	14 1/2	37 1/2	30 1/8	2,113
32	16	39 5/8	30 13/16	2,598

Class 600 Model FE 600 Wafer

Size Inches	Face to Face	Outside Dia.	Min. Flange Bore	Shipping Weight (lbs)
2	2 3/8	4 3/8	2 3/8	6
3	2 7/8	5 7/8	3 3/4	13
4	3 1/8	7 5/8	4 1/2	25
6	5 3/8	10 1/2	6 5/8	68
8	6 1/2	12 5/8	8 5/8	127
10	8 3/8	15 3/4	10 3/4	261
12	9	18	12 5/8	324
14	10 3/4	19 3/8	13 3/4	359
16	12	22 1/4	16 11/16	683
18	14 1/4	24 1/8	18	794
20	14 1/2	26 7/8	20 1/4	1,159
24	17 1/4	31 1/8	23 3/4	1,842
26	18	34 1/8	24 3/4	2,474
28	19	36	27 5/8	2,715
30	19 7/8	38 1/4	30 1/8	3,211
32	21	40 1/4	30 13/16	3,747

Class 900 Model FE 900 Wafer

Size Inches	Face to Face	Outside Dia.	Min. Flange Bore	Shipping Weight (lbs)
2	2 3/4	5 5/8	2 3/8	16
3	3 1/4	6 5/8	3 3/4	19
4	4	8 1/8	4 1/2	38
6	6 1/4	11 3/8	6 5/8	101
8	8 1/8	14 1/8	8 5/8	213
10	9 1/2	17 1/8	10 3/4	433
12	11 1/2	19 5/8	12 5/8	640
14	14	20 1/2	13 3/4	855
16	15 1/8	22 5/8	16 11/16	1,123
18	17 3/4	25 1/8	18	1,624
20	17 3/4	27 1/2	20 1/4	1,951
24	19 1/2	33	23 3/4	3,079

Class 1500 Model FE 1500 Wafer

Size Inches	Face to Face	Outside Dia.	Min. Flange Bore	Shipping Weight (lbs)
2	2 3/4	5 5/8	2 3/8	16
3	3 1/4	6 7/8	3 3/4	21
4	4	8 1/4	4 1/2	40
6	6 1/4	11 1/8	6 5/8	101
8	8 1/8	13 7/8	8 5/8	213
10	9 3/4	17 1/8	10 3/4	463
12	12	20 1/2	12 5/8	678
14	14	22 3/4	13 3/4	1,045
16	15 1/8	25 1/4	16 11/16	1,240
18	18 7/16	27 3/4	18	2,102
20	21	29 3/4	20 1/4	4,643

Class 2500 Model FE 2500 Wafer

Size Inches	Face to Face	Outside Dia.	Min. Flange Bore	Shipping Weight (lbs)
2	2 3/4	5 3/4	2 3/8	30
3	3 3/8	7 3/4	3 3/4	46
4	4 1/8	9 1/4	4 1/2	92
6	6 1/4	12 1/2	6 5/8	190
8	8 1/8	15 1/4	8 5/8	285
10	10	18 3/4	10 3/4	555
12	12	21 5/8	12 5/8	814
14	14	22 3/4	13 3/4	1,254
16	15 1/8	25 1/4	16 11/16	1,488
18	18 7/16	27 3/4	18	2,522
20	21	29 3/4	20 1/4	5,571

NOTE: Manufacturer reserves the right to modify dimensions, materials, or design. Contact factory for certification.

Installation Dimensions for Lug Body ANSI Check Valves

Class 150 Model FE 150 Lug				
Size Inches	Face to Face	Outside Dia.	Min. Flange Bore	Shipping Weight (lbs)
2	2 3/8	6	2 3/8	18
3	2 7/8	7 1/2	3 3/4	30
4	2 7/8	9	4 1/2	48
6	3 7/8	11	6 5/8	81
8	5	13 1/2	8 5/8	159
10	5 3/4	16	10 3/4	235

Class 300 Model FE 300 Lug				
Size Inches	Face to Face	Outside Dia.	Min. Flange Bore	Shipping Weight (lbs)
2	2 3/8	6 1/2	2 3/8	20
3	2 7/8	8 1/4	3 3/4	35
4	2 7/8	10	4 1/2	58
6	3 7/8	12 1/2	6 5/8	114
8	5	15	8 5/8	197
10	5 3/4	17 1/2	10 3/4	291

Installation Dimensions for Flanged Body ANSI Check Valves

Class 150 Model FE 150 Flanged				
Size Inches	Face to Face	Outside Dia.	Min. Flange Bore	Shipping Weight (lbs)
12	7 1/8	19	12 5/8	230
14	7 1/4	21	13 11/16	283
16	7 1/2	23 1/2	16 11/16	364
18	8	25	18	438
20	8 5/8	27 1/2	20 1/4	569
24	8 3/4	32	23 3/4	784
26	11 1/4	34 1/4	24 3/4	1,316
28	12 5/8	36 1/2	27 5/8	1,472
30	12	38 3/4	30 1/8	1,576
32	14	41 3/4	30 11/16	2,135
36	14 1/2	46	34	2,682
40	17	50 3/4	38 13/16	3,600
42	17	53	41 13/16	4,177
48	20 5/8	59 1/2	47	6,386
54	21 1/4	66 5/8	50 1/2	8,164

Class 300 Model FE 300 Flanged				
Size Inches	Face to Face	Outside Dia.	Min. Flange Bore	Shipping Weight (lbs)
12	7 1/8	20 1/2	12 5/8	261
14	8 3/4	23	13 3/4	405
16	9 1/8	25 1/2	16 11/16	519
18	10 3/8	28	18	711
20	11 1/2	30 1/2	20 1/4	936
24	12 1/2	36	23 3/4	1,417
26	14	38 1/4	24 3/4	1,796
28	15	40 3/4	27 5/8	2,181
30	14 1/2	43	30 1/8	2,343
32	16	45 1/4	30 13/16	2,861

Class 600 Model FE 600 Flanged				
Size Inches	Face to Face	Outside Dia.	Min. Flange Bore	Shipping Weight (lbs)
12	9	22	12 5/8	415
14	10 3/4	23 3/4	13 3/4	577
16	12	27	16 11/16	835
18	14 1/4	29 1/4	18	1,164
20	14 1/2	32	20 1/4	1,417
24	17 1/4	37	23 3/4	2,249
26	18	40	24 3/4	2,745
28	19	42 1/4	27 5/8	3,236
30	19 7/8	44 1/2	30 1/8	3,752
32	21	47	30 13/16	4,420

NOTE: Manufacturer reserves the right to modify dimensions, materials, or design. Contact factory for certification.

Check Valves

Head Loss - For Water at 60°F

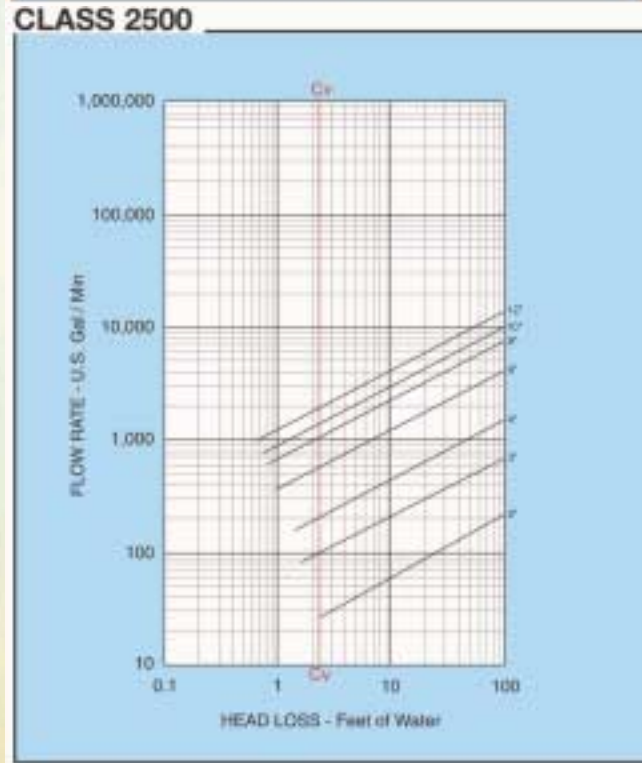
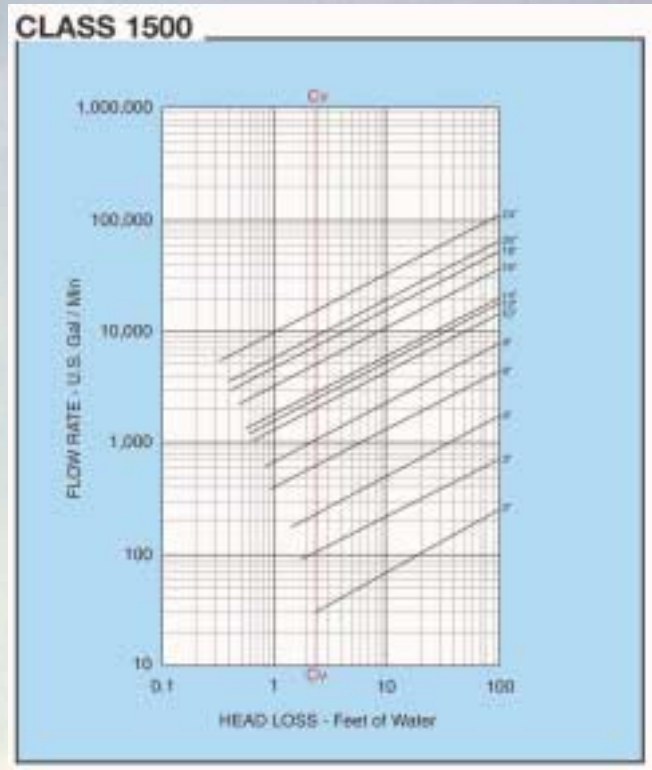
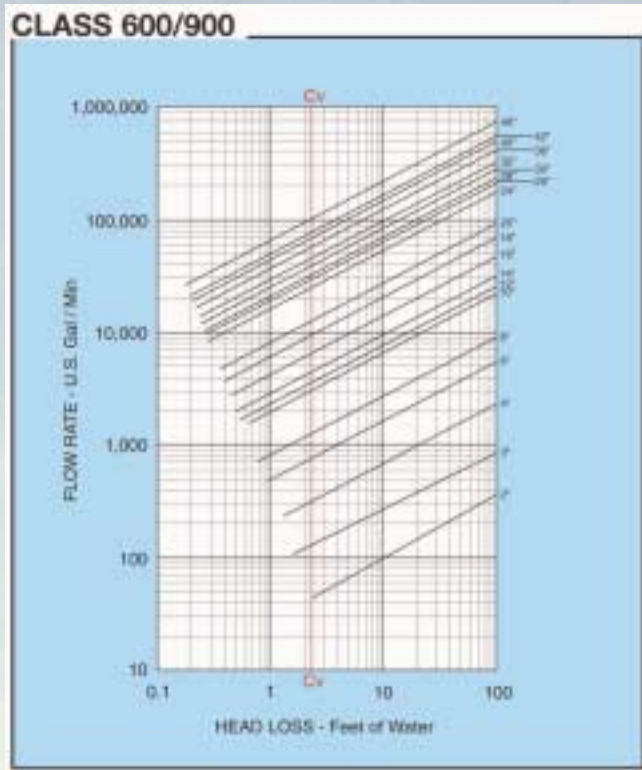

NOTE: Manufacturer reserves the right to modify dimensions, materials, or design. Contact factory for certification.

*Valves fitted to larger bore pipes will have lower pressure drops

**Note: For Class 150 refer to page 10

ANSI Stud Bolting

Valve Size	Class 125				Class 150				Class 300				Class 600				Class 900				Class 1500				Class 2500			
2	4	5/8	5 1/4	4	5/8	5 1/2	6	8	5/8	5 3/4	6 3/4	8	5/8	6 1/2	7	8	7/8	8 1/2	8 3/4	8	7/8	8 1/2	8 3/4	8	1	9 3/4	10	
3	4	5/8	5 3/4	4	5/8	6 1/2	7	8	3/4	7	8	8	3/4	7 3/4	8 1/4	8	7/8	9	9 1/4	8	1 1/8	10 1/4	10 1/2	8	1 1/4	12	12 1/4	
4	8	5/8	6 1/4	8	5/8	6 1/2	7	8	3/4	7 1/4	8 1/4	8	7/8	9 1/4	9 1/2	8	1 1/8	10 3/4	11	8	1 1/4	11 3/4	12	8	1 1/2	14	14 1/2	
6	8	3/4	7	8	3/4	7 3/4	8 1/4	12	3/4	8 3/4	9 3/4	12	1	12	12 1/2	12	1 1/8	14	14	12	1 3/8	16 1/2	16 3/4	8	2	20	20 1/2	
8	8	3/4	8	8	3/4	9 1/4	9 3/4	12	7/8	10 1/2	11 1/4	12	1 1/8	14 1/4	14 1/2	12	1 3/8	16 3/4	17 1/4	12	1 5/8	19 1/2	20	12	2	23 1/4	24	
10	12	7/8	9	12	7/8	10 1/2	11	16	1	12	12 3/4	16	1 1/4	16 3/4	17 1/4	16	1 3/8	18 3/4	19	12	1 7/8	23 1/4	23 1/2	12	2 1/2	29 1/2	30 1/4	
12	12	7/8	10 1/2	12	7/8	11 3/4	12 1/4	16	1 1/8	13 3/4	14 3/4	20	1 1/4	17 3/4	18	20	1 3/8	21 1/2	21 3/4	16	2	27	27 1/2	12	2 3/4	33 1/2	34 1/2	
14	12	1	12	12	1	12 1/4	13 1/4	20	1 1/8	16 1/4	16 1/4	20	1 3/8	20	20	-	-	-	-	-	-	-	-	-	-	-	-	-
16	16	1	13 1/4	16	1	13 1/4	14 1/2	20	1 1/4	16 3/4	16 3/4	20	1 1/2	22 1/2	22 1/2	-	-	-	-	-	-	-	-	-	-	-	-	-
18	16	1 1/8	14	16	1 1/8	14	15 1/4	24	1 1/4	19	19	20	1 5/8	24 1/2	24 1/2	-	-	-	-	-	-	-	-	-	-	-	-	-
20	20	1 1/8	14 1/4	20	1 1/8	14 1/2	15 1/2	24	1 1/4	20 1/4	21 1/4	24	1 5/8	26	27	-	-	-	-	-	-	-	-	-	-	-	-	-
24	20	1 1/4	16 1/2	20	1 1/4	16 3/4	16 3/4	24	1 1/2	22 1/2	22 1/2	24	1 7/8	30 1/2	30 1/2	-	-	-	-	-	-	-	-	-	-	-	-	-

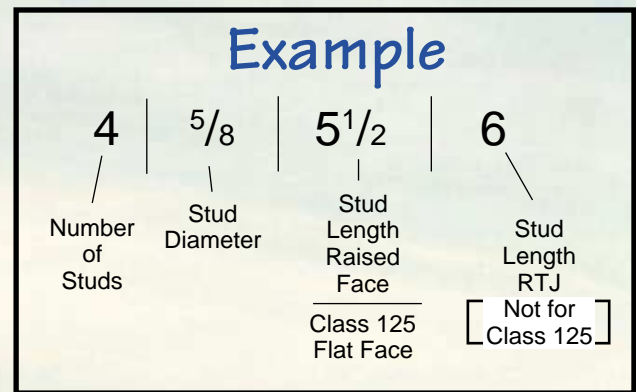

Installation Data

The valve is designed so that it is centralized between the flanges when the stud bolts are in position. The outside diameter of the body is equal to the bolt circle PCD minus the diameter of one bolt.

It is suitable for use in a variety of orientations. In horizontal lines the valve is installed with the pins vertical (i.e. with the pin retainers at the top). For sizes 6" and upwards the valve is tapped to take an eyebolt for lifting.

Arrows cast into the body indicate the normal direction of flow.

Before initial installation it is advisable to open the plates by hand since, if the valve is held in store for a period of time, the corrosion inhibitor may have caused the plates to stick to the body and line pressure may not be sufficient to break this seal.

If the bottom half of the studs are installed first they will serve as a platform to support the valve whilst the gaskets and other studs are put in. Similarly, if the valve is to be removed from the line, the top half of the studs should be removed and the bottom half slackened.

Check Valves

Pressure Loss Through Valves

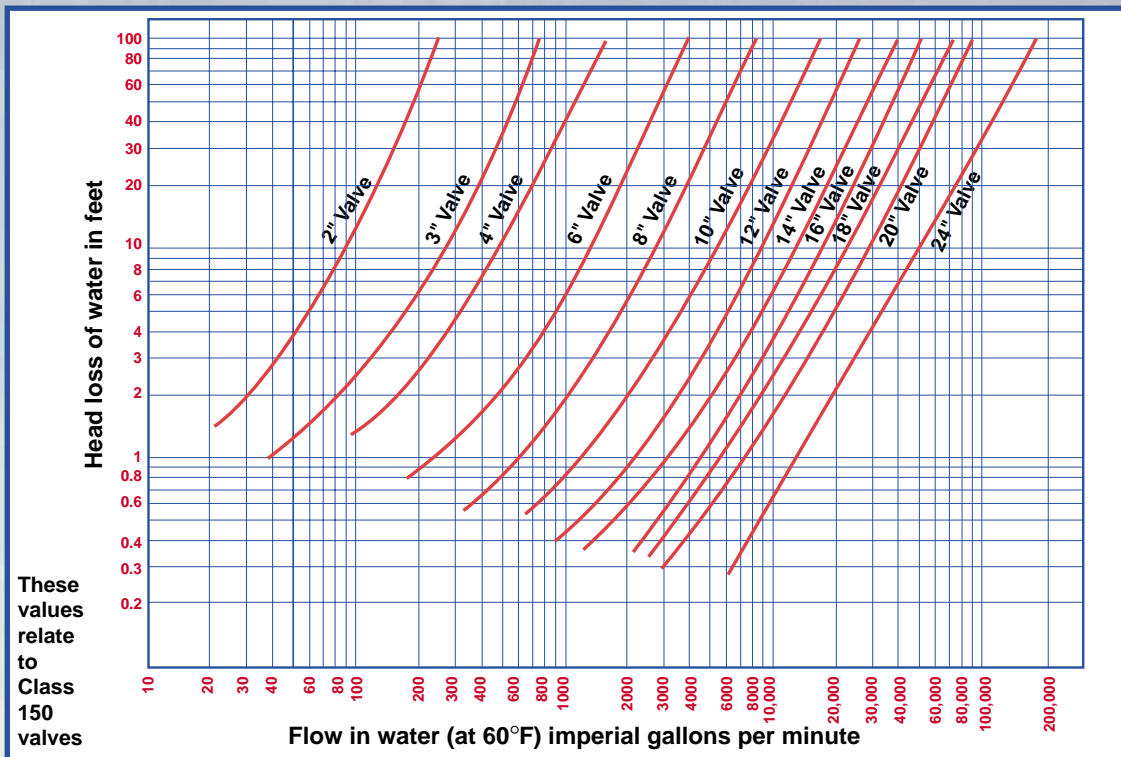

- ◆ We will provide valves to match your performance requirements
- ◆ The curves shown above relate to valves provided with standard rated springs
- ◆ Higher value springs may be required to ensure faster reaction if very large changes in velocity occur
- ◆ It should be borne in mind that a media (liquid) velocity in the pipeline of 10 ft per second is considered to be desirable for normal applications

**Percent of Flow Area
Sure Flow Check vs Standard Steel Pipe**

Size	Pressure Class					
	150	300	600	900	1500	2500
2"	36.7	36.7	44.0	54.4	54.4	36.1
3"	39.1	39.1	43.8	46.6	46.6	32.8
4"	41.4	41.4	45.8	47.7	47.7	29.5
6"	54.0	54.0	58.5	52.9	52.9	33.4
8"	56.7	56.7	57.8	58.6	58.6	32.7
10"	56.0	56.0	67.9	70.5	52.6	30.9
12"	61.8	61.8	63.0	71.8	62.0	31.2
14"	66.7	72.5	62.9	75.4	75.4	—
16"	64.3	55.2	67.9	71.8	71.8	—
18"	74.5	69.9	64.8	76.4	74.0	—
20"	70.8	65.1	67.4	84.0	81.0	—
24"	66.0	63.4	68.3	71.4	71.0	—

Approximate performance data for Sure Flow Check valves when used with water at 60° F with a nominal 10 ft/sec velocity

Valve Size	Flow (imperial gals/min)	Pressure drop psi	Head loss in feet	Approx. equiv. length of pipe in feet
2"	86	4.49	10.32	30
3"	192	2.97	6.83	34
4"	368	2.30	5.29	35
6"	750	1.47	3.38	37
8"	1292	1.20	2.76	40
10"	2116	0.93	2.14	41
12"	2920	0.81	1.87	44
14"	3570	0.74	1.70	45
16"	4750	0.60	1.38	47
18"	6600	0.55	1.27	47
20"	7500	0.51	1.18	50
24"	12500	0.42	0.97	52

Seat Options

The right seat is critical for the correct functioning of the valve in its designated service. offers a wide range of seat options.

Metal to metal seats can be either the body/plate parent material or a hardfacing of other material, overlaid by deposition.

For soft seated valves standard elastomers are vulcanized for maximum security.

On high pressure class valves it is set into a groove for further safety.



Simple Installation

Simplicity and speed of installation are of paramount importance for the process or pipeline engineer. is simply installed between the flanges. A raised face (serrated or smooth finish), a RTJ, profile hub and butt weld ends can be provided. Only one set of studs is required as fits inside the bolt circle PCD. If the valve needs to be taken out of the line, only half the bolts need to be removed, reducing the amount of work to be done and providing a retained link for the two pipe flanges.

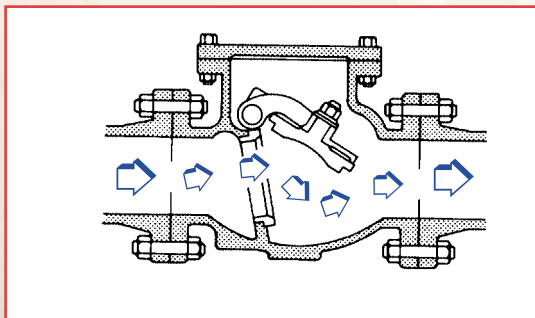

Conventional swing check valve

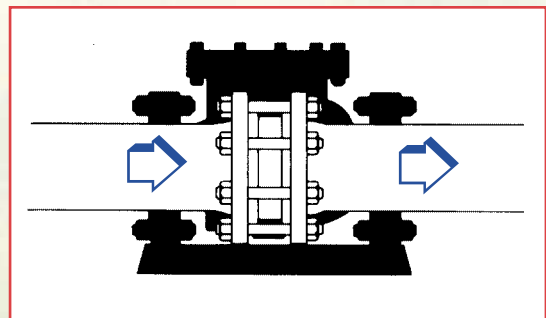

Horizontal Flow - rib vertical

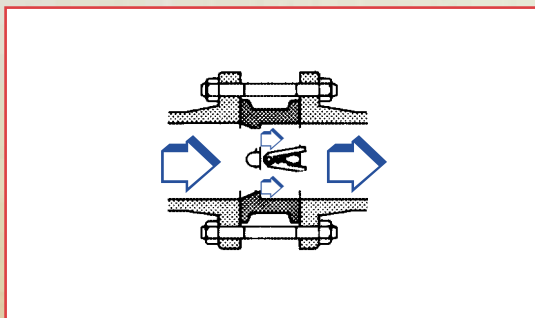

Sure Flow Check dual plate wafer check valve

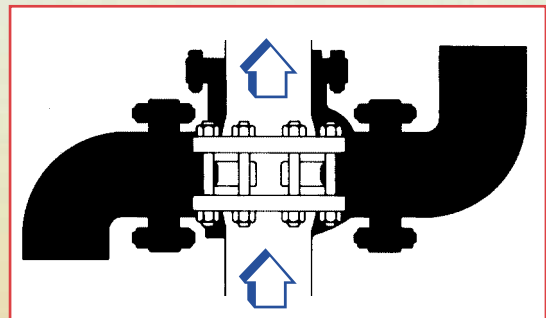

Vertical Flow

Check Valves

Quality From Start To Finish

Quality Counts

Our quality starts with design and engineering, continues through development and testing, to manufacture and certification. Our technical and sales support services are vital ingredients in maintaining the overall quality of our products. The stringent quality control, inspection and testing procedures we apply are contained within the Documented Quality System.

*Manufactured to API 594
and tested to API 598*

Quality is manufactured not inspected

Our operatives are responsible for the quality and accuracy of their work and for ensuring that it is in accordance with the appropriate working drawings and specifications. Our Q.A. Department checks initial compliance throughout all aspects of manufacture from the receipt of materials to the end of the machining process.

Our Quality Assurance Department remains the ultimate authority in guaranteeing that materials, engineering and methods are in full accordance with agreed specifications and established procedures. Through a combination of these procedures we can confidently fulfil all requirements for material conformity and traceability and for full certification.

When you specify valves, you can be confident that not only are you making an investment in quality and reliability, but equally important, you know the service starts with the sale.

*All requirements for
material conformity,
traceability and certification
met in full*



Type CD125IS Wafer - Double Door - Dual Disc- Check Valve



The **Eco (Economical) Dual Plate Check Valve** features ease of maintenance and exceptional flow characteristics.

- Body gives compact, one-piece wafer design
- Dual plate valves give maximum strength with minimum opening time
- Full contact seats maintain positive shut-off at minimum working pressure
- Torsion springs assist valve closure, preventing flow reversal
- Shaft is of extra heavy duty, corrosion resistant construction
- Shaft supports with large bearings act as stops to prevent over travel of plates
- Thrust washers reduce friction and wear of valve plate hinges.
- Model CD125IS with 316SS Discs

Operating Pressures and Temperatures

Service	Size	psi	Temp
WOG	2" - 12"	200	200°F
WOG	14" - 54"	150	200°F

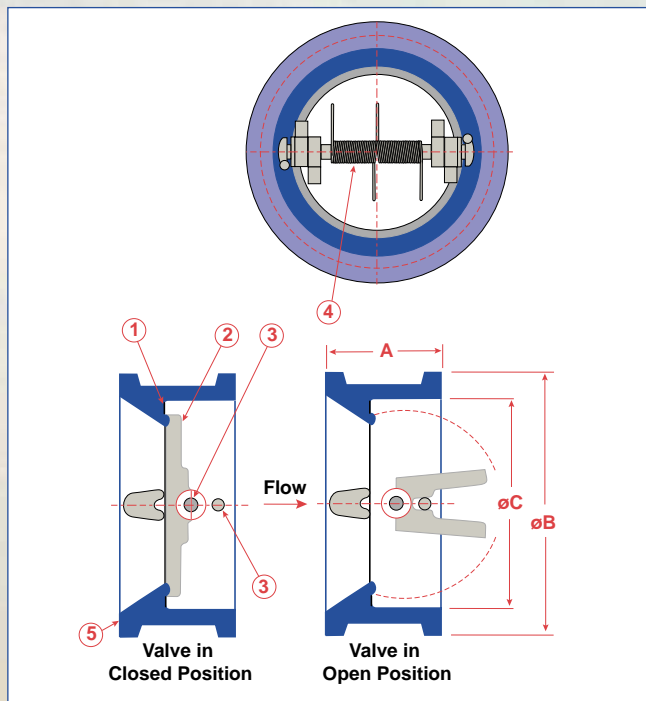

Ordering Information

Example: Include full description

Size (Prefix) Model #

0400 - CD125IS

4", Cast Iron Wafer Check Valve,
BUNA-N Seat, 316SS Discs.

Notes

Manufacturer reserves the right to modify dimensions, materials, or design. Contact factory for certification. Valves are designed to operate on vertical and horizontal flow, see note 1.

NOTE 1

Horizontal Flow: Valve must be installed with disc hinge pin in the vertical position, to insure proper operation.

Construction

No	Name	Material
1	Seat/Seal	Buna-N
2	Discs	A351 Gr. CF8M Stainless Steel
3	Shaft	A351 Gr. CF8M Stainless Steel
4	Torsion Spring	A351 Gr. CF8M Stainless Steel
5	Cast Body	A126 Class B Cast Iron

Dimensional Data

Size Inches	Model	A	B	C	Shipping Weight (lbs)
2	0200	2 1/8	4 1/8	2 3/8	6
2 1/2	0250	2 1/8	4 7/8	2 5/16	7
3	0300	2 1/4	5 3/8	3 3/4	10
4	0400	2 1/2	6 3/8	4 1/2	14
5	0500	2 3/4	7 11/16	5 11/16	19
6	0600	3	8 3/4	6 5/8	25
8	0800	3 3/4	11	8 5/8	42
10	1000	4 1/4	13 3/8	10 3/4	72
12	1200	5 5/8	16	12 5/8	116
14	1400	7 1/4	16 5/8	13 11/16	182
16	1600	7 1/2	20 1/2	16 11/16	243
18	1800	8	21 5/8	18	334
20	2000	8 3/8	23 7/8	20 1/4	430
24	2400	8 3/4	28 1/4	23 3/4	582
26	2600	11 1/4	30 1/2	24 3/4	1,128
28	2800	12 5/8	32 3/4	27 5/8	1,293
30	3000	12	34 13/16	30 1/8	1,356
32	3200	14 1/2	37	30 11/16	1,746
36	3600	14 1/2	41 1/4	34	2,125
40	4000	16	45 3/4	38 13/16	3,011
42	4200	17	48	41 13/16	3,795
48	4800	20 5/8	54 1/2	47	5,566
54	5400	21 1/4	60 7/8	50 1/2	6,831

Elastic Swing Check Valves

Ductile Iron - Flanged

Type CXF125IV Flanged Elastic Swing Check Valve



The **Elastic Swing Check Valve** is suitable for municipal and industrial applications.

It is standard with a ductile iron body with flanges which comply with ANSI B16.1; Class 125. The internal body is epoxy coated. Special coatings are available upon request. The one-piece molded disc has a steel reinforced insert to insure closure. Plus, while in the open position, it will allow 100% uninterrupted flow. The one-piece disc hinge and disc can be repaired without removal of the valve from the line.

The elastic check can be installed in a vertical or horizontal pipeline.

Construction

No	Name	Material
1	Cast Body	A536 60-45-12
2	Cover	A536 60-45-12
3	Disc	BUNA w/steel & fabric reinforcement
4	Gasket	Lexide NK-511 (non asbestos)
5	Cover Bolts	Alloy steel SAE Grade S
6	Drain	A536 60-45-12

*Face to face: ANSI B16.10 Class 125

Operating Pressures and Temperatures

Service	Size	psi	Temp
WOG	2" - 12"	285	150°F
WOG	14" - 24"	150	150°F

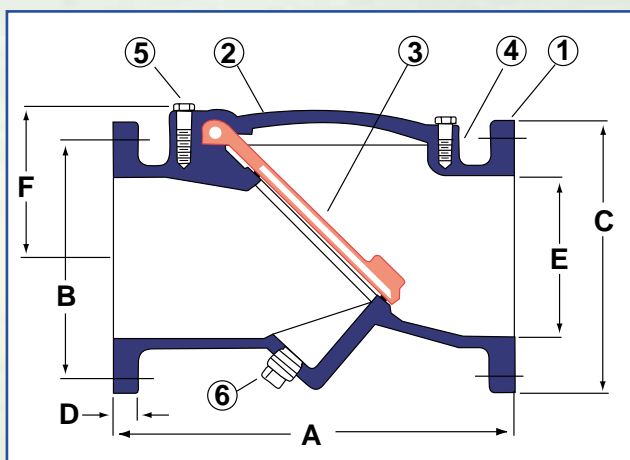

Dimensional Data

Size Inches	Model	A	B	C	D	E	F	Drain Size	Shipping Weight (lbs)
2	0200CXF125IV	8	4 3/4	6	5/8	2	3 3/8	3/4	30
2 1/2	0250CXF125IV	8 1/2	5 1/2	7	11/16	2 1/2	3 3/8	3/4	38
3	0300CXF125IV	9 1/2	6	7 1/2	3/4	3	3 7/8	3/4	46
4	0400CXF125IV	11 1/2	7 1/2	9	15/16	4	4 5/8	1	70
5	0500CXF125IV	13 3/4	8 1/2	10	15/16	5	5 1/8	1	100
6	0600CXF125IV	15	9 1/2	11	1	6	5 7/8	1 1/4	115
8	0800CXF125IV	19 1/2	11 3/4	13 1/2	1 1/8	8	7 5/8	1 1/2	250
10	1000CXF125IV	24 1/2	14 1/4	16	1 3/16	10	9 7/8	2 1/2	525
12	1200CXF125IV	27 1/2	17	19	1 1/4	12	11 1/2	2 1/2	710
14	1400CXF125IV	31	18 3/4	21	1 3/8	14	13 1/2	2 1/2	860
16	1600CXF125IV	31 15/16	21 1/4	23 1/2	1 7/16	16	15 1/4	2 1/2	1090
18	1800CXF125IV	35 15/16	22 3/4	25	1 9/16	18	17 1/4	3	1450
20	2000CXF125IV	39 15/16	25	27 1/2	1 11/16	20	19 1/4	3	1575
24	2400CXF125IV	47 15/16	29 1/2	32	1 7/8	24	22 3/4	3	2600

Ordering Information

Example: Include full description

Size (Prefix) Model #

0400 - CXF125IV

4", Ductile Iron Flanged Check Valve,
BUNA-N w/steel & fabric reinforcement



Notes

Manufacturer reserves the right to modify dimensions, materials, or design. Contact factory for certification.

Type CSF125IB Flanged Horizontal Swing Check Valve



The **Sure Flow Horizontal Swing Check Valve** has a cast iron body, cover and disc. The valve is provided with a bronze seat ring and bronze disc ring.

Bronze being softer than a cast iron facing, it offers a more positive sealing effect than competitors' standard iron facing. At the same time, a bronze seat ring and disc ring is very versatile in its stability to temperature and various commonly handled materials.

Conforming to MSS SP-71

End Flange Dimensions: ANSI B16.1

Face to Face Dimensions: ANSI B16.10.

Construction

No	Name	Material
1	Cover Bolt & Nut	Steel
2	Cover	A126 Class B
3	Gasket	Graphite
4	Hanger Pin	Stainless Steel
5	Hanger	A126 Class B
6	Disc Ring	B62
7	Disc	A126 Class B
8	Disc Washer	Steel
9	Disc Bolt	Steel
10	Seat Ring	B62
11	Cast Body	A126 Class B

Operating Pressures and Temperatures

Service	Size	psi	Temp
WOG	2" - 12"	200	200°F
WOG	14" - 20"	150	200°F

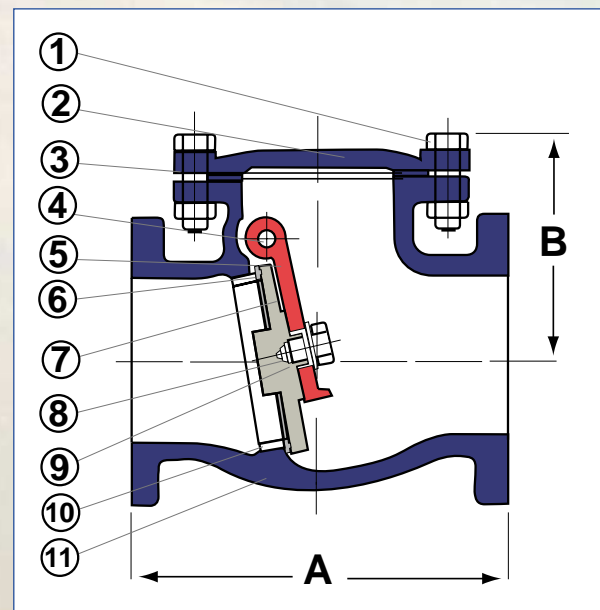

Dimensional Data

Size Inches	Model	A	B	Shipping Weight (lbs)
2	0200CSF125IB	8	5 1/8	20
2 /12	0250CSF125IB	8 1/2	5 5/8	25
3	0300CSF125IB	9 1/2	6 1/8	30
4	0400CSF125IB	11 1/2	7 1/8	70
5	0500CSF125IB	13	9	88
6	0600CSF125IB	14	9 1/4	98
8	0800CSF125IB	19 1/2	10 7/8	130
10	1000CSF125IB	24 1/2	12 1/4	300
12	1200CSF125IB	27 1/2	13 3/4	410
14	1400CSF125IB	31	18 1/4	496
16	1600CSF125IB	30 1/4	19 1/2	660
18	1800CSF125IB	33	21	825
20	2000CSF125IB	36	23 1/2	981

Ordering Information

Example: Include full description

Size Model
(Prefix) #

0400 - CSF125IB

4", Cast Iron Flanged Horizontal Swing Check Valve, Bronze Seat Ring

Notes

Manufacturer reserves the right to modify dimensions, materials, or design. Contact factory for certification.

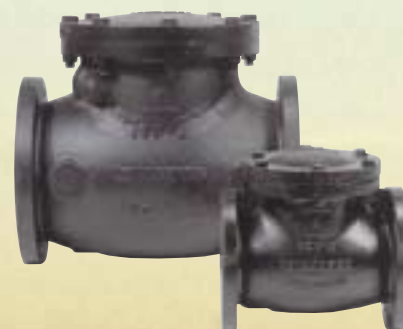

Check Valves

Cast Iron - Swing Disc

Type CSW125IS Wafer Swing Check Valve ANSI 125/150 Class



The **Wafer Swing Check Valve** incorporates several features distinguishing it from conventional check valves for silent, fast, non slam operation. The most prominent of these is the accurately machined disc and its special quick closing action. Spring loading of the 316SS disc assures instantaneous closure to reversing flow, preventing build-up of momentum, the cause of damaging water hammer. The hinge pin design assures free movement of the disc and eliminates seizure under extreme conditions. Soft seat inserts are standard for positive sealing of hard-to-hold solvents and fluids. Lifting eye hook on 8" to 12" valves.

Operating Pressures and Temperatures

Service	Size	psi	Temp
WOG	2" - 12"	200	100°F

Construction

No	Name	Material
1	Torsion Spring	316 Stainless Steel
2	Plug	ASTM A126 Class B
3	O-Ring Seal	BUNA-N
4	Cast Body	ASTM A126 Class B
5	Shaft	316 Stainless Steel
6	Disc	316 Stainless Steel

Dimensional Data

Size Inches	Model	A	B	C	D	Shipping Weight (lbs)
2	0200CSW125IS	4 1/8	2 1/4	1 1/2	7/8	10
2 1/2	0250CSW125IS	4 7/8	2 3/8	1 3/4	1	12
3	0300CSW125IS	5 3/8	2 5/8	2 1/8	1 1/2	17
4	0400CSW125IS	6 7/8	2 1/4	3 1/8	2 1/4	26
5	0500CSW125IS	7 3/4	2 1/2	3 7/8	2 1/2	36
6	0600CSW125IS	8 3/4	2 3/4	4 3/4	2 3/4	53
8	0800CSW125IS	11	2 7/8	6 1/2	4	72
10	1000CSW125IS	13 3/8	3 1/8	7 3/4	7 3/16	115
12	1200CSW125IS	16 1/8	3 3/8	9 1/2	9	168

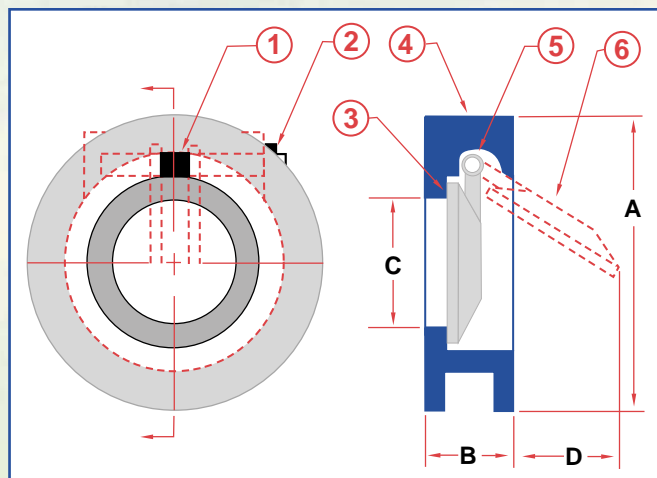

Notes

Manufacturer reserves the right to modify dimensions, materials, or design. Contact factory for certification.

Valves are designed to operate on vertical and horizontal flow, see note 1.

NOTE 1

The wafer check valve is designed for installation between two pipe flanges in horizontal or vertical pipelines (in the latter case upward flow is preferred).



Ordering Information

Example: Include full description

Size (Prefix) Model #

0400 - CSW125IS

4", Cast Iron Wafer Swing Check Valve, BUNA-N Seat, 316SS Disc

Type CSW150SSMIR Wafer Swing Check Valve ANSI 150 Class



The **Wafer Swing Check Valve** incorporates several features distinguishing it from conventional check valves for silent, fast, non slam operation. The most prominent of these is the accurately machined disc and its special quick closing action. Spring loading of the 316SS disc assures instantaneous closure to reversing flow, preventing build-up of momentum, the cause of damaging water hammer. The hinge pin design assures free movement of the disc and eliminates seizure under extreme conditions. Metal seat is standard for sealing. Lifting eye hook on 8" to 12" valves.

Operating Pressures and Temperatures

Service	Size	psi	Temp
WOG	2" - 12"	275	100°F

Construction

No	Name	Material
1	Torsion Spring	Inconel X 316 SS
2	Bolt	316 SS
3	Seat	CF8M
4	Cast Body	CF8M
5	Shaft	316 SS
6	Disc	CF8M
7	Eye Bolt	Carbon Steel Zinc Plated

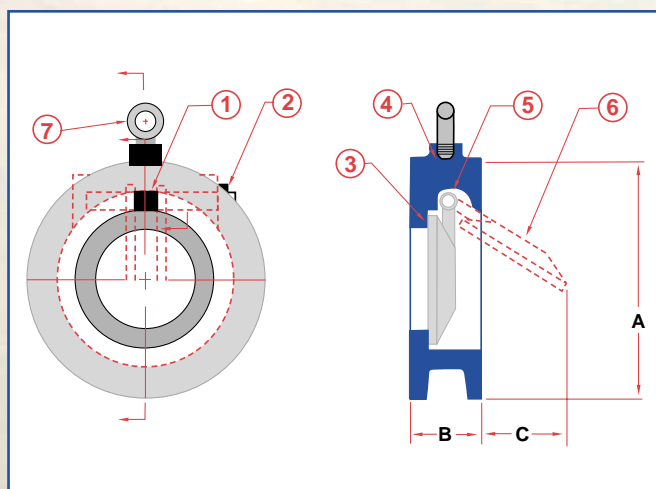

Dimensional Data

Size Inches	Model	A	B	C	Shipping Weight (lbs)
2	0200CSW150SS	4 1/8	2 3/8	1 1/8	8
3	0300CSW150SS	5 3/8	2 7/8	1 1/2	16
4	0400CSW150SS	6 7/8	2 7/8	2 3/8	26
6	0600CSW150SS	8 3/4	3 7/8	3 3/4	55
8	0800CSW150SS	11	5	4	103
10	1000CSW150SS	13 3/8	5 3/4	5 7/16	143
12	1200CSW150SS	16 1/8	7 1/8	5 7/8	252

Ordering Information

Example: Include full description

Size (Prefix) Model #

0400 - CSW150SSMIR

4", 316SS Wafer Swing Check Valve,
Metal Seat, 316SS Disc

Notes

Manufacturer reserves the right to modify dimensions, materials, or design. Contact factory for certification.

Valves are designed to operate on vertical and horizontal flow, see note 1.

NOTE 1

The wafer check valve is designed for installation between two pipe flanges in horizontal or vertical pipelines (in the latter case upward flow is preferred).

*Please specify metal or viton seal.



Silent Check Valves

Cast Iron - Wafer

Type CW125ISC - Cast Iron Flat Face



Operating Pressures and Temperatures

Service	Size	psi	Temp.
Liquid	2" - 12"	200	180°F

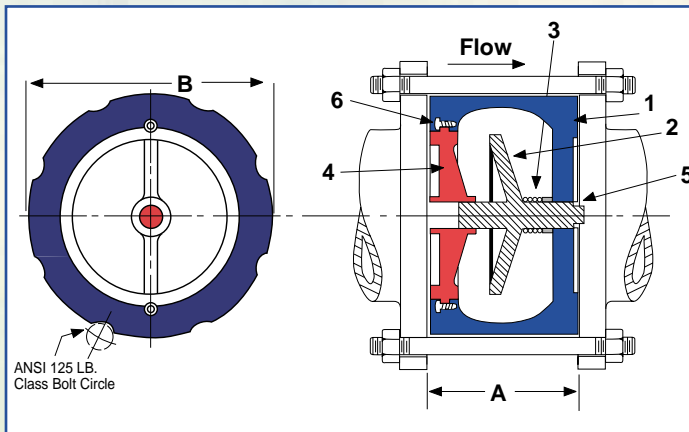

Ordering Information

Example: Include full description

Model # Type & Material

0400 - CW125ISC

4", Flat Face Wafer Check Valve Silent, Stainless Steel Plug

Consult factory for optional construction materials and installation instructions. Resilient seating of BUNA-N or VITON available for 4" size and larger.

Sure Flow Wafer Check Valves are designed to close before the pump stops completely. This prevents flow reversal which eliminates water hammer and system surges associated with valve closure.

- Quiet Operation
- Guided Discs
- Vertical or Horizontal Installation
- Sizes 2" thru 12"

Service Applications

- Municipal Water Systems
- Industrial Class HVAC - Liquid Service
- Industrial Piping Systems
- Irrigation Systems

Construction

No	Name	Material
1	Cast Body	A126 Class B
2	Plug	A351 Gr. CF8M
3	Spring	Stainless Steel
4	Seat	A351 Gr. CF8M
5	Bushing	Stainless Steel
6	Screw	Stainless Steel

Dimensional Data

Size	Model	A	B	CV	Shipping Weight (lbs)
2	0200CW125ISC	2 5/8	4	40	7
2 1/2	0250CW125ISC	2 7/8	4 3/4	60	9
3	0300CW125ISC	3 1/8	5 1/4	85	15
4	0400CW125ISC	4	6 3/4	150	25
5	0500CW125ISC	4 5/8	7 5/8	230	32
6	0600CW125ISC	5 1/2	8 5/8	340	56
8	0800CW125ISC	6 1/2	10 3/4	600	100
10	1000CW125ISC	8 1/4	13 1/8	900	140
12	1200CW125ISC*	11 1/4	19	1850	370*

*Special full lug pattern

Notes

Manufacturer reserves the right to modify dimensions, materials, or design. Contact factory for certification.

The Flow Coefficient (Cv) is the number of gallons per minute of water flowing through a given size restriction at a pressure drop of one psi. To obtain the Cv factor for a given size check valve refer to table above.



We recommend that the valves be installed 7 to 10 pipe lengths away from the turbulence.

Silent Check Valves

Cast Steel & Cast Stainless Steel Wafer

Type CW150C - Cast Steel & CW150SS Cast Stainless Steel



Sure Flow Wafer Check Valves are designed to close before the pump stops completely. This prevents flow reversal which eliminates water hammer and system surges associated with valve closure.

- Quiet Operation
- Guided Discs
- Vertical or Horizontal Installation
- Sizes 2" thru 24"

Service Applications

- Municipal Water Systems
- Industrial Class HVAC - Liquid Service
- Industrial Piping Systems
- Irrigation Systems

Operating Pressures and Temperatures

Material	Service	Size	psi	Temp.
Cast Steel	Liquid	2" - 10"	285	100°F
Stainless Steel	Liquid	2" - 10"	275	100°F

Construction - Cast Steel

No	Name	Material
1	Cast Body	A216 Gr. WCB
2	Plug	A351 Gr. CF8M
3	Spring	Stainless Steel
4	Seat	A351 Gr. CF8M
5	Bushing	Stainless Steel
6	Screw	Stainless Steel

Construction - Cast Stainless Steel

All ASTM Spec A351 Grade CF8M Stainless Steel.

Dimensional Data

Size	Model	A	B	CV	Shipping Weight (lbs)
2	0200CW150	2 5/8	4 1/4	50	7
2 1/2	0250CW150	2 7/8	5	72	9
3	0300CW150	3 1/8	5 3/4	92	15
4	0400CW150	4	7	180	25
5	0500CW150	4 5/8	8 3/8	276	32
6	0600CW150	5 1/2	9 3/4	408	56
8	0800CW150	6 1/2	13 1/2	720	100
10	1000CW150	8 1/4	16	1000	140

* Also Available in size 12", 14", 16", 18", 20" and 24".

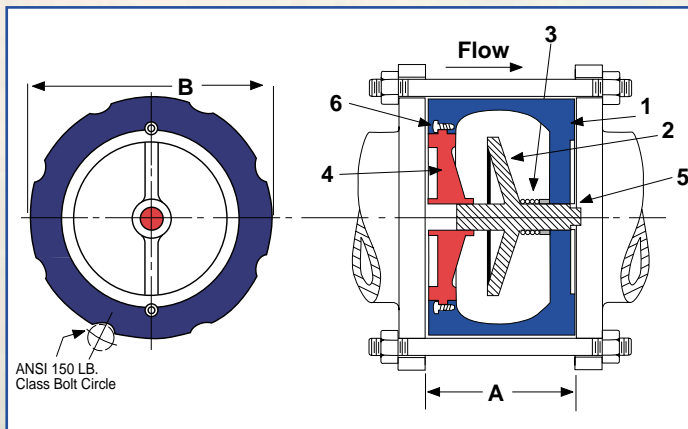

Ordering Information

Example: Include full description

Model # Type & Material

0400 - CW150SS150

4", Raised Face Wafer Silent Check Valve, All 316SS Construction

Consult factory for optional construction materials and installation instructions. Resilient seating of BUNA-N or VITON available for 4" size and larger.

We recommend that the valves be installed 7 to 10 pipe lengths away from the turbulence.

Notes

Manufacturer reserves the right to modify dimensions, materials, or design. Contact factory for certification.

The Flow Coefficient (Cv) is the number of gallons per minute of water flowing through a given size restriction at a pressure drop of one psi. To obtain the Cv factor for a given size check valve refer to table above.



Globe or Silent Check Valves

Cast Iron - Flanged

Type CF125ISC Cast Iron



Operating Pressures and Temperatures

Service	Size	psi	Temp.
Liquid	2" - 16"	200	150°F
Liquid	14" - 24"	150	150°F

Sure Flow Globe Style Check Valves are designed to close before the pump stops completely. This prevents flow reversal which eliminates water hammer and system surges associated with valve closure.

- Quiet Operation
- Guided Discs
- Vertical or Horizontal Installation
- Sizes 2" thru 24"

Service Applications

- Municipal Water Systems
- Industrial Class HVAC - Liquid Service
- Industrial Piping Systems
- Irrigation Systems

Construction

No	Name	Material
1	Body	A126 Class B
2	Plug	Stainless Steel
3	Spring	Stainless Steel
4	Seat	Stainless Steel
5	Bushing	Stainless Steel
6	Screw	Stainless Steel
7	Quad Ring	BUNA-N (Optional)

Dimensional Data

Size	Model	A 316SS Plug CF125ISC	CV	Shipping Weight (lbs)
2	0200CF125ISC	6 1/4	40	30
2 1/2	0250CF125ISC	7	100	34
3	0300CF125ISC	7 1/2	130	50
4	0400CF125ISC	8 1/2	225	75
5	0500CF125ISC	9 1/2	340	100
6	0600CF125ISC	10 1/2	540	130
8	0800CF125ISC	13 1/2	830	240
10	1000CF125ISC	16 1/4	1370	360
12	1200CF125ISC	20 1/4	1980	600
14	1400CF125ISC	22 3/4	2300	710
16	1600CF125ISC	24 3/4	3200	810
18	1800CF125ISC	22 1/2	6200	910
20	2000CF125ISC	24	6800	1140
24	2400CF125ISC	24	9800	2600

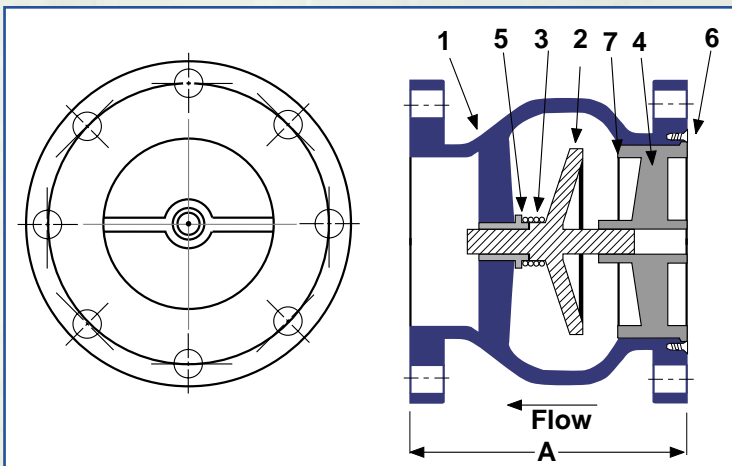

Ordering Information

Example: Include full description

Size (Prefix) Model #

0400 - CF125ISC

4", Flat Face Flanged Cast Iron Silent Check Valve with 316SS Disc

Consult factory for optional construction materials and installation instructions. Resilient seating of BUNA-N or VITON available for 4" sizes and larger.

We recommend that the valves be installed 7 to 10 pipe lengths away from the turbulence.

Notes

Manufacturer reserves the right to modify dimensions, materials, or design. Contact factory for certification.

The Flow Coefficient (Cv) is the number of gallons per minute of water flowing through a given size restriction at a pressure drop of one psi. To obtain the Cv factor for a given size check valve refer to table above.



Silent Check Valves

Cast Steel, Cast Stainless Steel - Flanged

Type CF150C Cast Steel, Type CF150SSC Stainless Steel



Sure Flow Globe Style Check Valves are designed to close before the pump stops completely. This prevents flow reversal which eliminates water hammer and system surges associated with valve closure.

- Quiet Operation
- Guided Discs
- Vertical or Horizontal Installation
- Sizes 2" thru 12"

Service Applications

- Municipal Water Systems
- Industrial Class HVAC - Liquid Service
- Industrial Piping Systems
- Irrigation Systems

Construction - Cast Steel

No	Name	Material
1	Body	SA216 Gr. WCB
2	Plug	Stainless Steel
3	Spring	Stainless Steel
4	Seat	Stainless Steel
5	Bushing	Stainless Steel
6	Screw	Stainless Steel

Operating Pressures and Temperatures

Material	Service	Size	psi	Temp.
Cast Steel	Liquid	2" - 12"	285	100°F
Stainless Steel	Liquid	2" - 12"	275	100°F

Construction - Cast Stainless Steel

All ASTM Spec A351 Grade CF8M Stainless Steel.

Dimensional Data

Size	Model	A	CV	Shipping Weight (lbs)
2	0200CF150	6 1/4	55	30
2 1/2	0250CF150	7	90	41
3	0300CF150	7 5/8	140	56
4	0400CF150	8 1/2	265	90
6	0600CF150	10 1/2	610	150
8	0800CF150	12	1000	260
10	1000CF150	14	1700	410
12	1200CF150	18	2400	720

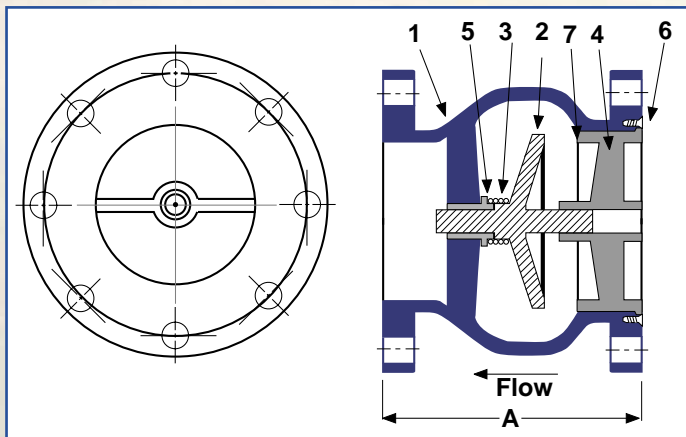

Ordering Information

Example: Include full description

Size (Prefix) Model #
0400 - CF150C

4", 150# Raised Face Cast Steel - Silent Check Valve

Consult factory for optional construction materials and installation instructions. Resilient seating of BUNA-N or VITON available for 4" size and larger.

We recommend that the valves be installed 7 to 10 pipe lengths away from the turbulence.

Notes

Manufacturer reserves the right to modify dimensions, materials, or design. Contact factory for certification.

The Flow Coefficient (Cv) is the number of gallons per minute of water flowing through a given size restriction at a pressure drop of one psi. To obtain the Cv factor for a given size check valve refer to table above.



Silent Check Valves

Pressure Drop in Water

Silent Check Valves

Wafer Style

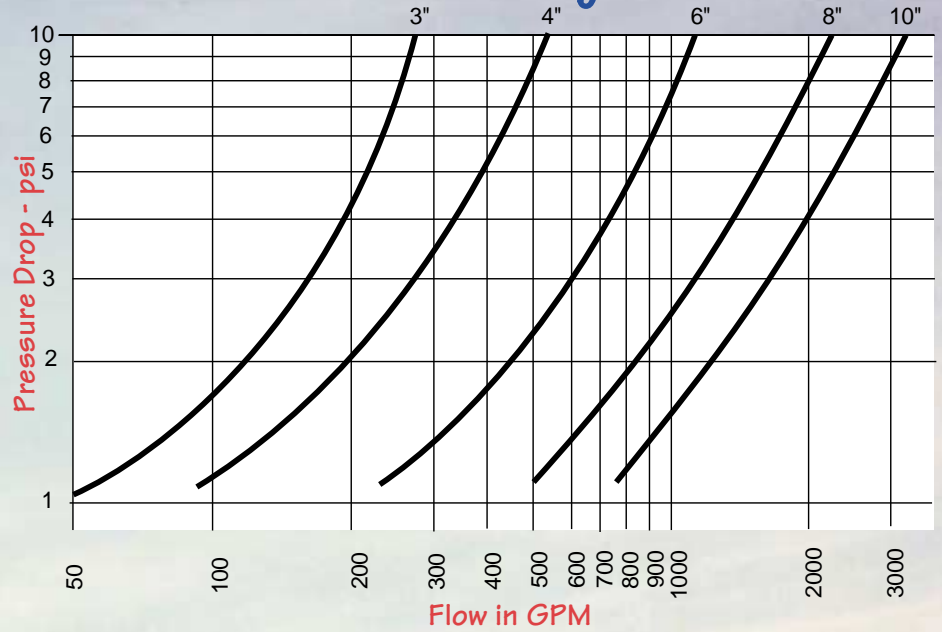

Globe Style

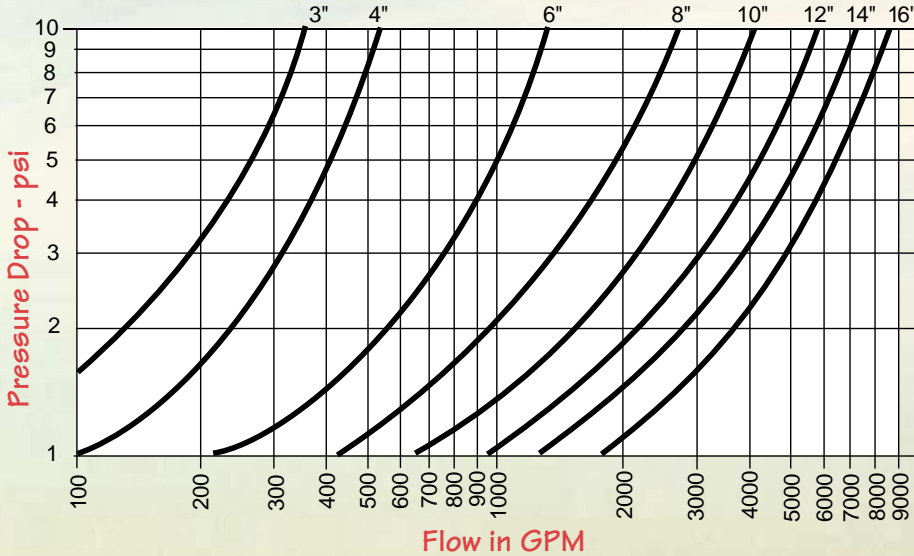

- The above curves are based on the flow of clean water at ambient temperature.
- Preferred piping standards recommend placing check valves 5 to 10 pipe diameters from any turbulence producing device, i.e. pumps, elbows, etc.
- Maximum recommended flow velocity of 10 ft./sec.

We recommend that the valves be installed 7 to 10 pipe lengths away from the turbulence.

Elastic Swing Foot Valves

Ductile Iron - Flanged

Type FVCEXF-125 Flanged Elastic Swing Foot Valve



The Elastic Swing Foot Valve is suitable for municipal and industrial applications.

It is standard with a ductile iron body with flanges which comply with ANSI B16.1; Class 125 or 250. The internal body is epoxy coated. Special coatings are available upon request. The one-piece molded disc has a steel reinforced insert to insure closure. Plus, while in the open position, it will allow 100% uninterrupted flow. The one-piece disc hinge and flapper can be repaired without removal of the valve from the line. The Elastic Swing Foot Valve is designed for continuous flow applications and is not recommended for reciprocating pumps.

The elastic swing foot valve can be installed in a vertical or horizontal pipeline.

The Elastic Swing Foot Valve body material is Ductile Iron ASTM SA536 60-45-12 with a screen of 1/8" perforated Stainless Steel.

Operating Pressures and Temperatures

Service	Size	psi	Temp
WOG	2" - 12"	200	150°F
WOG	14" - 24"	150	150°F

Dimensional Data

Size		A	B	C	D	CV	Shipping Weight lbs
Inches	Prefix						
2	0200	8	10 1/2	3	6 1/8	150	36
2 1/2	0250	8 1/2	11	3	7 1/8	305	46
3	0300	9 1/2	12	3	7 5/8	600	55
4	0400	11 1/2	14	3	9 1/8	955	84
5	0500	13 3/4	16 3/4	4	10 1/8	1400	120
6	0600	15	19 1/2	5	11 1/8	2800	138
8	0800	19 1/2	25	6	13 5/8	5000	300
10	1000	24 1/2	31	7	16 1/8	8000	630
12	1200	27 1/2	35	8	19 1/8	9000	852
14	1400	31	39 1/2	9	21 1/8	10,000	1,032
16	1600	31 15/16	41 7/16	10	23 5/8	15,000	1,308
18	1800	35 15/16	47 7/16	12	25 1/8	18,000	1,740
20	2000	39 15/16	55 7/16	16	27 5/8	28,000	1,890
24	2400	47 15/16	65 7/16	18	32 1/8	40,000	3,120

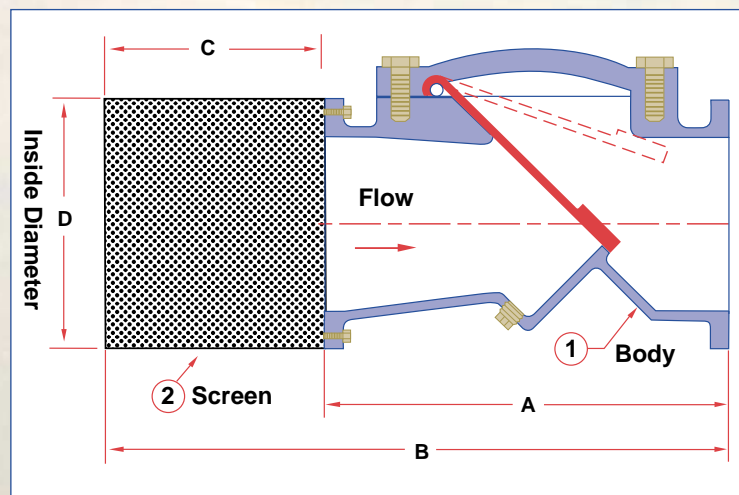

Ordering Information

Example: Include full description

Size (Prefix) Model #

0400 - FVCEXF-125

4" Ductile Iron Flanged Elastic Swing Foot Valve, Buna-N w/Steel Disc

Notes

Manufacturer reserves the right to modify dimensions, materials, or design. Contact factory for certification.

The Flow Coefficient (Cv) is the number of gallons per minute of water flowing through a given size restriction at a pressure drop of one psi.

NOTE 1

Horizontal Flow: Valve must be installed with cover on top, to insure proper operation.



Elastic Hinge Foot Valves

Cast Steel, Cast Stainless Steel - Flanged

Type FVRF-150CC Carbon Steel Foot Valves and Type FVRF-150SS Stainless Steel Flanged Foot Valves



The Elastic Hinge Foot Valve is suitable for municipal and industrial applications. It is available in Threaded style in sizes from one inch to four inches and in Flanged style in sizes from one inch to twelve inches. Units are supplied standard with Buna seals and 316SS flappers.

The elastic hinge design provides the highest flow factor "Cv" of all the foot valves available from Sure Flow. The Elastic Hinge Foot Valve is seatless, full port, and features a double disc check valve - the next generation of continuous flow internal design that offers high pressure rating and improved flow characteristics.

Standard screen is 0.125" perf. (40% open) with a 6:1 open area ratio. The screen material is 316SS. Other screen openings are available upon request.

NOTE: Foot Valve will operate in either the horizontal or vertical position.

Construction

Model	Body / Internals Materials
FVRF-150CC	Carbon Steel/316SS
FVRF-150SS	316SS

Standard hardware is 316 SS
Standard seal material is Buna-N

Operating Pressures and Temperatures

Type	Size	psi	Temp
WOG	1" - 12"	200	150°F

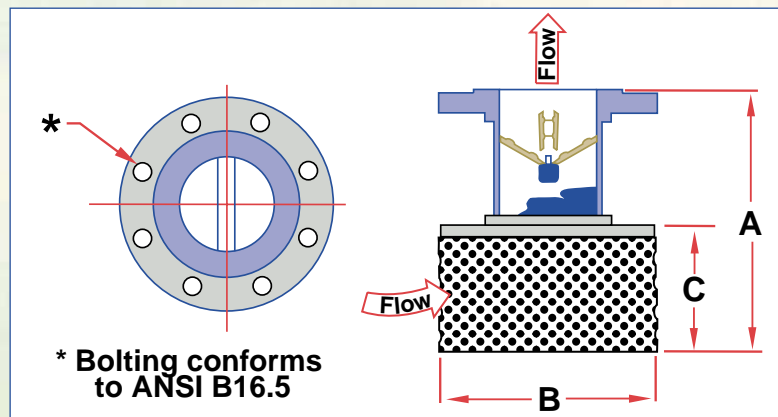

Dimensional Data

Size		A	B	C	Shipping Weight lbs	CV
Inches	Prefix					
1	0100	8 1/4	1 3/4	5	4	37
1 1/4	0125	8 1/4	2	5	5	65
1 1/2	0150	9 3/4	2 3/8	6	7	91
2	0200	10 3/4	2 7/8	7	10	160
2 1/2	0250	13 1/8	3 3/8	8	11	410
3	0300	15 1/2	4 1/8	10	15	620
4	0400	13	9	8	42	965
5	0500	15 1/2	10	10	49	1510
6	0600	17 1/2	12 1/2	11	72	3025
8	0800	24 1/2	15	16	115	5195
10	1000	31 1/2	17 1/2	21	168	7345
12	1200	38 1/2	20 1/2	26	276	9450

Ordering Information

Example: Include full description

Size Model
(Prefix) #

0400 - FVRF-150CC

4" Carbon Steel Flanged Foot Valve,
Buna-N Seal w/Stainless Steel Disc.
Consult factory for optional
construction materials. Resilient
seating of EPDM, and Teflon.

Notes

Manufacturer reserves the right to modify dimensions, materials, or design. Contact factory for certification.

The Flow Coefficient (Cv) is the number of gallons per minute of water flowing through a given size restriction at a pressure drop of one psi.



Elastic Hinge Foot Valves

Cast Steel, Cast Stainless Steel - Threaded



Type FVRM-150CC Carbon Steel and FVRM-150SS Stainless Steel Male Threaded Foot Valves

The Elastic Hinge Foot Valve is suitable for municipal and industrial applications.

It is available in Threaded style in sizes from one inch to four inches and in Flanged style in sizes from one inch to twelve inches. Units are supplied standard with Buna seals and 316SS flappers.

The elastic hinge design provides the highest flow factor "cv" of all the foot valves available from Sure Flow. The Elastic Hinge Foot Valve is seatless, full port, and features a double disc check valve - the next generation of continuous flow internal design that offers high pressure rating and improved flow characteristics.

Standard screen is 0.125" perf. (40% open) with a 6:1 open area ratio. The screen material is 316SS. Other screen openings are available upon request.

NOTE: Foot Valve will operate in either the horizontal or vertical position.

Construction

Model	Body / Internals Materials
FVRM-150CC	Carbon Steel/316SS
FVRM-150SS	316SS

Standard hardware is 316 SS
Standard seal material is Buna-N

Operating Pressures and Temperatures

Type	Size	psi	Temp
WOG	1" - 4"	200	150°F

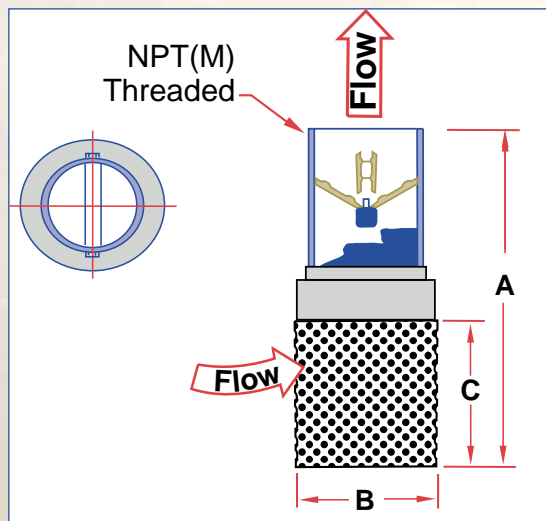

Dimensional Data

Size		A	B	C	Shipping Weight lbs	CV
Inches	Prefix					
1	0100	8 1/4	1 3/4	5	2	37
1 1/4	0125	8 1/4	2	5	2	65
1 1/2	0150	9 3/4	2 3/8	6	2	91
2	0200	10 3/4	2 7/8	7	3	160
2 1/2	0250	13 1/8	3 3/8	8	5	410
3	0300	15 1/2	4 1/8	10	8	620
4	0400	19 1/4	5 1/8	13	12	965

Notes

Manufacturer reserves the right to modify dimensions, materials, or design. Contact factory for certification.

The Flow Coefficient (Cv) is the number of gallons per minute of water flowing through a given size restriction at a pressure drop of one psi.



Ordering Information

Example: Include full description

Size (Prefix) Model #

0400 - FVRM-150CC

4" Carbon Steel Male Threaded Foot Valve, Buna-N Seal w/Stainless Steel Disc. Consult factory for optional construction materials. Resilient seating of EPDM and Viton.

Silent Seat Foot Valves

Cast Iron - Cast Steel - Stainless Steel - Flanged

Type FV 125 Cast Iron, Type FV150 Cast Steel,
Type FV150SS Stainless Steel Foot Valves



Construction

Design of the available in sizes 2 inches to 30 inches, evolved through a need for a valve that could provide positive sealing actions at various pressure ranges without seat damages, along with silent operation.

The , satisfies these requirements plus low head loss through its full ported area and heavy duty stainless steel basket screening.

The Buna-N O-ring, provides a drop-tight seal. As the pressure increases, the Buna-N O-ring is compressed slightly and the disc makes contact with the metal portion of the valve seat, preventing any further compression of the Buna-N O-ring. The Buna-N O-ring will continue to provide the "drop-tight seating" during the higher pressure ranges without damage from the increased pressure loading.

Standard Features:

- The seating design provides positive shut-off at all pressure ranges without additional loading on the seal.
- Heavy duty stainless steel screening, with flow area 3 to 4 times that of pipe area.
- Silent operation, by design of disc, stroke and linear closing characteristics.
- Cast iron, 125 lb ANSI Standard.

Optional Features:

- Available in carbon steel & stainless steel

Ordering Information

Example: Include full description

Size (Prefix)	Model #
1200 -	FV150

12" Carbon Steel Silent Seat Flanged
Foot Valve, Buna-N Seat



A foot valve should be used with basket strainers and check valves.

Notes

Manufacturer reserves the right to modify dimensions, materials, or design. Contact factory for certification.

Foot Valve Assembly

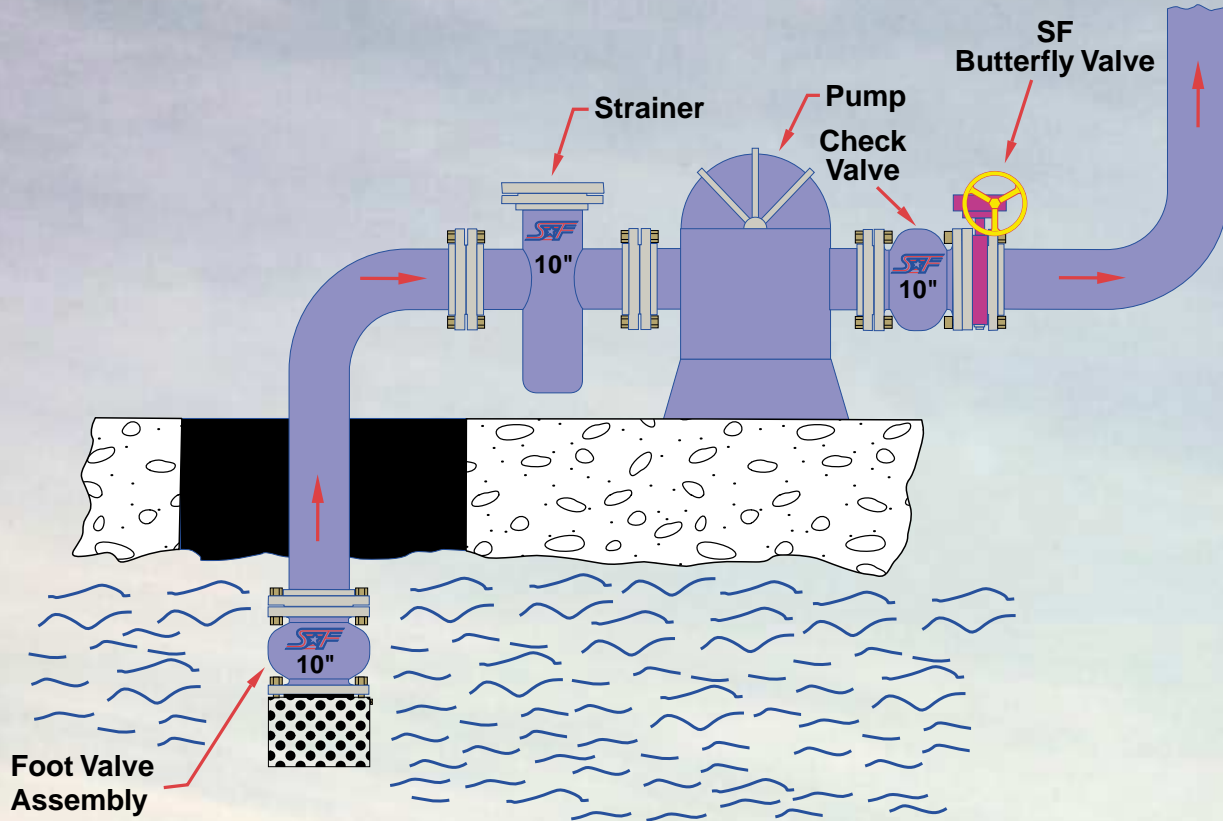

Construction - Cast Steel

No	Name	Material
1	Body Ass'y	A126 Class B
2	Quad Ring	Buna-N o-ring
3	Studs	SA 194 B7 Steel
4	Hex Nuts	SA 194 Steel
5	Slip-on Flng	Flat Face ASTM A105
6	Cap Screw	Stainless Steel
7	Screen	Stainless Steel
8	Gasket Ring	Red Rubber

Dimensional Data

Size		A	B	C	D	Shipping Wgt (lbs.)
Inches	Prefix					
2	0200	6	3	9 7/16	6	25
2 1/2	0250	7	3	10 3/16	7	35
3	0300	7 1/2	3	10 11/16	7 1/2	45
4	0400	9	3	11 11/16	9	70
5	0500	10	4	13 11/16	10	90
6	0600	11	5	15 11/16	11	110
8	0800	13 1/2	6	19 11/16	13 1/2	180
10	1000	16	7	23 7/16	16	250
12	1200	19	8	28 7/16	19	400

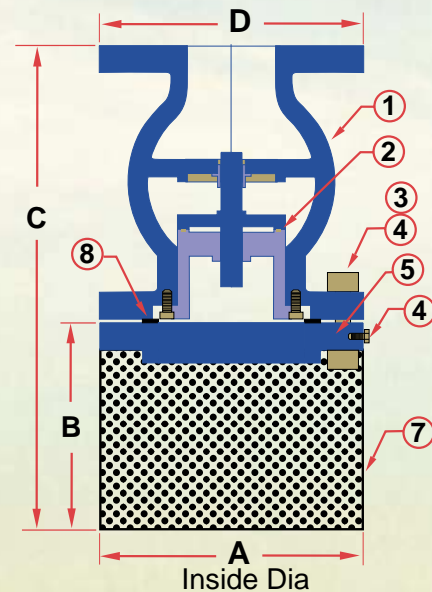

Notes:

Manufacturer reserves the right to modify dimensions, materials, or design. Contact factory for certification.

The Flow Coefficient (Cv) is the number of gallons per minute of water flowing through a given size restriction at a pressure drop of one psi.